

# Gravel Roads

## Part II

### Back to the Basics



Local Technical Assistance Program  
Department of Civil Engineering  
Montana State University-Bozeman  
Bozeman, MT

2000

## **Foreward**

The design stage of a gravel road is such a minor part of the overall process that maybe it shouldn't be mentioned. What is design anyway? The fact is, design entails not only drafting, surveying, materials, geometrics, safety, etc., but also includes how a road evolves and how it is maintained. Design of a gravel road is performed daily by the counties who enhance materials and drainage facilities, and reshape the gravel road with each motor grader pass. This is why the well trained grader operator is the designer as well as the expert of road maintenance.

The purpose of this manual is to assist beginning and experienced transportation providers in providing safe, long lasting local roads for the traveling public. The State of Montana has approximately 71,000 miles of roads. The Montana Department of Transportation maintains 8,100 miles, the cities maintain 2,500 miles, and counties and other agencies maintain 60,000 miles. Seventy-six percent of Montana's roads are unpaved. It is recognized that funds for the construction, maintenance and operation of the local road system are limited. Therefore, this handbook is based on the fact that proper road maintenance reduces costs while keeping the roads in a safe, good condition for longer periods of time.

Local officials should be aware that the public presently is spending more on county road accidents than they are on the roads themselves. In overall dollar terms about seventy million dollars are spent annually on accidents and only fifty million is spent on county roads. Thus, every operator should know the important part he can play in eliminating accidents. Sometimes people within the same road department do not agree on procedures. This can be a problem because one of the basic concepts of roadway safety is uniformity. The reason it is so important is that driver expectancy should be the same on all roads. Publishing this handbook is directed toward that end.

To be a good operator, you must expend a lot of time and effort. You need to know your equipment, your roads, proper operating procedures, the law, and the policies of your department.

Sam Gianfrancisco  
Local Technical Assisance Program

Steve Jenkins, P.E.  
Local Technical Assistance Program

# Table of Contents

<b>Chapter 1 - Drainage</b> .....	<b>1</b>
1.1 Highway Drainage .....	1
1.2 Road Base.....	3
1.3 Crowning.....	5
1.4 Ditches.....	7
1.5 Culverts.....	8
<b>Chapter 2 - Materials</b> .....	<b>16</b>
2.1 Introduction.....	16
2.2 Profile-Cross Section.....	17
2.3 Benefits of Testing Aggregate .....	18
2.4 Gradation.....	20
2.5 Moisture Content.....	22
2.6 Compactive Effort.....	23
2.7 Vegetation.....	24
2.8 Oversize Rock.....	25
2.9 New Gravel.....	26
2.10 Cost Comparison - Paved vs. Unpaved Roads.....	28
<b>Chapter 3 - Proper Blading Techniques</b> .....	<b>29</b>
3.1 Ditching.....	29
3.2 Two Pass Maintenance - Smoothing (Dragging) Gravel Roads.....	31
3.3 Six Pass Blading - Reshaping Gravel Roads.....	32
3.4 Intersections.....	34
3.5 Bridges & Cattle Guards.....	34
3.6 Maintaining Super-Elevation on Curves.....	34
3.7 Backsloping.....	36
3.8 Filter Fabrics: Installatiion of Geotextiles on Low Volume Roads.....	36
<b>Chapter 4 - Equipment Operation</b> .....	<b>41</b>
4.1 Walk-Around Check.....	41
4.2 Moldboards.....	42
4.3 Safety.....	46
<b>Chapter 5 - Maintenance of Unpaved Roads-Near Wetlands</b> .....	<b>48</b>
5.1 Introduction.....	48
5.2 Factors Influencing Erosion.....	51
5.3 Sedimentation.....	52
5.4 Types of Erosion.....	54
5.5 Stabilization.....	55
5.6 Sediment Control.....	57
5.7 Dust Control Practices.....	66

<b>Chapter 6 - Dust Control.....</b>	<b>68</b>
6.1 Road Dust Suppressants.....	68
6.2 Relative Effectiveness of Road Dust Suppressants.....	69
<b>References.....</b>	<b>81</b>
<b>Video Tape References.....</b>	<b>82</b>

# List of Figures & Tables

## Chapter 1

Figure 1.1	Water Cycle.....	1
Figure 1.2	Capillary Rise of Water Into Road Base.....	3
Figure 1.3	Moisture in Roadbase.....	4
Figure 1.4	Road Crowns.....	5
Table 1.1	Capacity of Steel Pipes.....	8
Figure 1.5	Improper Culvert Installation.....	9
Figure 1.6	Proper Culvert Installation.....	9
Figure 1.7	Placement of Culvert on Natural Drainage.....	10
Figure 1.8	Proper Culvert Length Needed.....	10
Figure 1.9	Poor Culvert Placement Under Intersecting Road.....	11
Figure 1.10	Proper Culvert Placement Under Intersecting Road.....	12
Figure 1.11	Using Natural Stream Bed as Drainage Outfall.....	13
Figure 1.12	Culvert Bedding.....	14
Figure 1.13	Trench Width.....	15

## Chapter 2

Figure 2.1	Edge of Road Maintenance.....	18
Figure 2.2	Uniform Material.....	20
Table 2.1	Recommended Gradation for Gravel Road Surface Material.....	21
Figure 2.3	Moisture Content vs. Overall Density.....	22
Table 2.2	Quantity of New Gravel.....	27
Figure 2.4	Spreading of New Gravel.....	27

## Chapter 3

Figure 3.1	Marker Pass.....	30
Figure 3.2	Bringing Material Shoulder to Centerline.....	31
Figure 3.3	Two-Pass Maintenance.....	32
Figure 3.4	Six-Pass Maintenance Shaping a Road.....	33
Figure 3.5	Super-elevation on Curves.....	35
Figure 3.6	Backsloping.....	36
Table 3.1	Characteristics of Geotextile Materials for a Roadbed.....	37
Table 3.2	Material Placed on Geotextiles.....	39

## Chapter 4

Figure 4.1	Blade Pitch.....	43
Figure 4.2	Angle of Moldboard.....	43

## Chapter 5

Figure 5.1	Regulations Flow Chart.....	50
Figure 5.2	Placement of Gravel Filter Berms.....	56
Figure 5.3	Suggested Size of Berms.....	57
Figure 5.4	Cleaning Ditches Beneath a Cut.....	57

Figure 5.5 Use of Silt Fences.....	58
Figure 5.6 Placement of Silt Fence.....	59
Figure 5.7 Placement of Straw Bales.....	60
Figure 5.8 Function of Straw Bales.....	61
Figure 5.9 Cross Section of Water Steps.....	63
Figure 5.10 Design of Drainage Outfalls.....	63

## Chapter 6

Table 6.1 ASTM, Tests of.....	71
Figure 6.1 Grain Size Distribution.....	72
Figure 6.2 Schematic Diagram of the Colorado State University Dustometer Setup.....	73
Table 6.2 Average Daily Traffic Per Section.....	74
Figure 6.3 Amount of Dust Collected.....	74
Table 6.3 Inches of Dust Estimated Per Year.....	75
Table 6.4 Tons of Aggregate Lost.....	76
Table 6.5 Cost Per Mile to Maintain Test Sections.....	77
Figure 6.4 Cost of Maintenance vs. ADT.....	79
Table 6.6 Average Daily Traffic When Dust Treatment Becomes Feasible.....	79

# Chapter 1

## Drainage

### 1.1 Highway Drainage

It has often been said that the three most important aspects of road engineering are drainage, drainage and drainage. Without good surface and subsurface drainage, the best of materials, even when accompanied by good construction

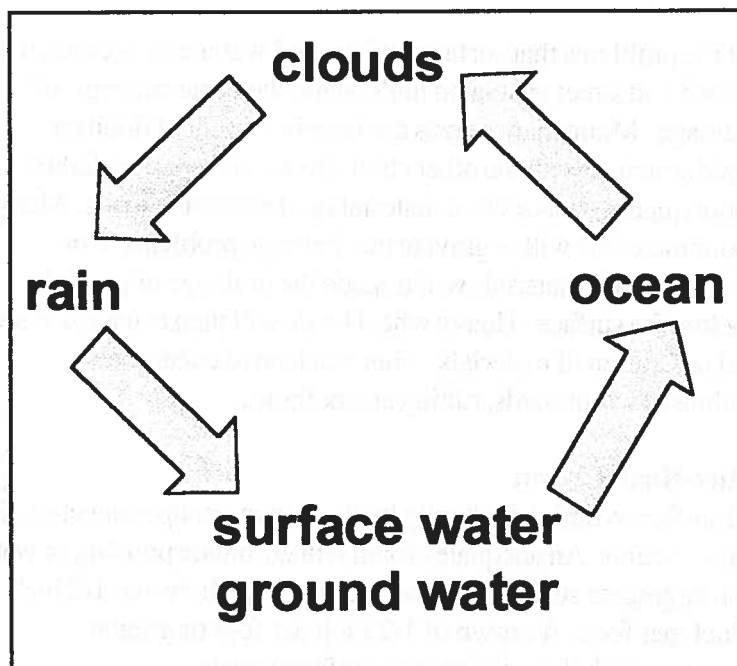

Figure 1.1-Water Cycle

methods, will result in a road with a very short life. Wash boards and eventually potholes, are the result of bases and subgrades weakened by water. Water pools on the road surface and wheelpath ruts filled with water create hydroplaning and skidding hazards.

#### A Detailed Look at the Hydrologic Cycle

Water that falls to the ground in the form of rain, snow or ice goes through a natural cycle, flowing overland as runoff or through the soil as ground water. It may eventually reach an area where it will evaporate into the atmosphere. The water vapor will condense to form clouds and return to the earth in the form of precipitation. This cycle is shown in Figure 1.1, and is a process that takes place continuously.

#### Problems Associated with Moisture

Although necessary and desirable, the hydrologic cycle can create problems for the road user, the road official, and property owners near the roadways. Very often roads and streets will disrupt the normal surface and subsurface flow of water. This will create drainage problems that must be solved by the road official. With the help of nature, water will seek its own most efficient path of flow, the one of least resistance. The road or street official will often need to build drainage structures to force the flow along alternate and artificial paths. In providing alternate flow paths we disrupt the natural flow, often creating problems of erosion, silting and changes in the ground water table that come back to haunt us later.



The precipitation associated with the hydrologic cycle can create some rather serious problems.

- A safety hazard due to decreased visibility in heavy rain.
- The possibility of hydroplaning due to standing water on the road surface.
- A reduction in friction between tire and road resulting in increased stopping distance.
- Erosion problems due to excessive stream velocity.
- Reduction in the strength of the road structure and accelerated deterioration of the road surface due to accumulated moisture in the materials that support the road.
- Failure of drainage structures due to large flow volumes and their associated forces during exceptional storm events.
- Frost damage due to excessive moisture in silty upgrade soils.

Considering all of the problems that surface and ground water can present, it is important for the road and street official to understand the basic concepts of hydrology and drainage. Maintenance costs are largely a result of drainage problems in the road structure with the other chief causes of pavement failure being the use of poor quality construction materials and excessive loads. Many times the use of poor materials will aggravate the drainage problems. For example, the use of poor base materials will impede the drainage of ground water in the soil below the surface. Heavy wheel loads will then cause excessive pore pressures and repulsion of materials. This will lead to excessive deflections and failure as washboards, rutting and potholes.

### **Drainage Facilities-Road Crown**

Water on the road surface is drained laterally by the crown or superelevation that is built into the cross section. An adequate crown will eliminate ponding of water on the surface. An aggregate surface requires a cross slope between 1/2 inch per foot and 3/4 inch per foot. A crown of 1/2 inch per foot or greater essentially will eliminate potholes on aggregate surfaced roads.

### **Surface Materials**

For an aggregate surfaced road to shed the rain water, it must have an impervious surface with at least 10 percent fines in the material. Surface aggregates with few fines will allow the water to infiltrate into the subsoils and cause deformation (rutting) of the road surface. In addition, a surface with few fines lacks enough binder to hold it together when dry and the surface will be pushed off the travel surface by traffic (Local Roads Program, Highway Drainage, 1987).



## 1.2

**Road Base**

A good base of large free draining material will ensure that a gravel road has bearing capacity to handle heavy loads and lasting drainage capability. Angular large road base (1 to 3 inches) distributes tires forces out over a large area so that natural earth can bear heavy weights without damaging the road. A good base will prevent rutting and support finer grained surfacing. A base free of fines will not allow capillary rise of water from high water tables that may occur seasonably (see Figure 1.2). It is estimated that if after a heavy storm you can get a road base to drain 85% within five hours, your road will be protected from rutting that occurs on saturated and muddy roads (see Figure 1.3).

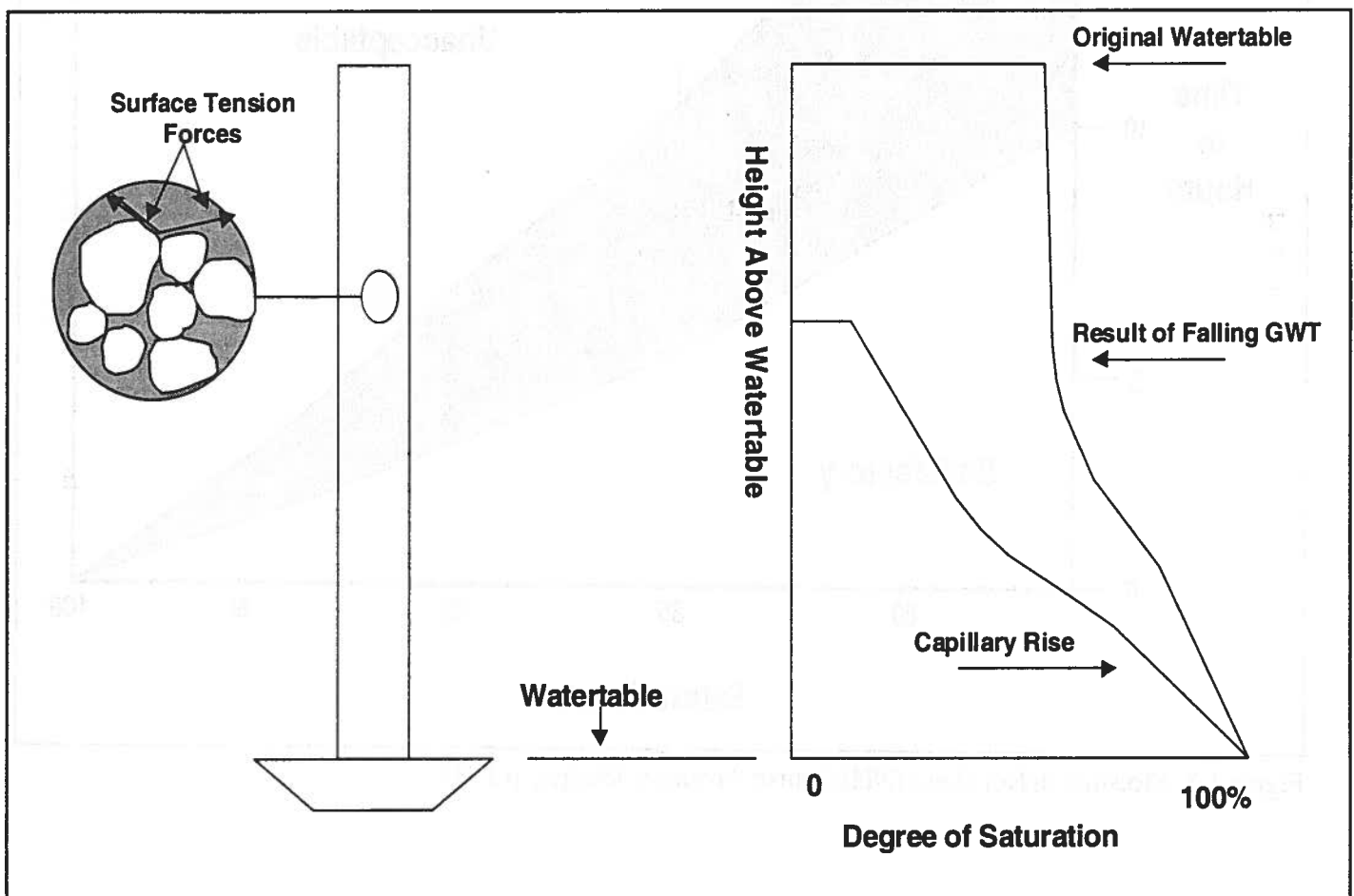

Figure 1.2- Capillary Rise of Water Into Road Base (Pavement Design, September 1987)

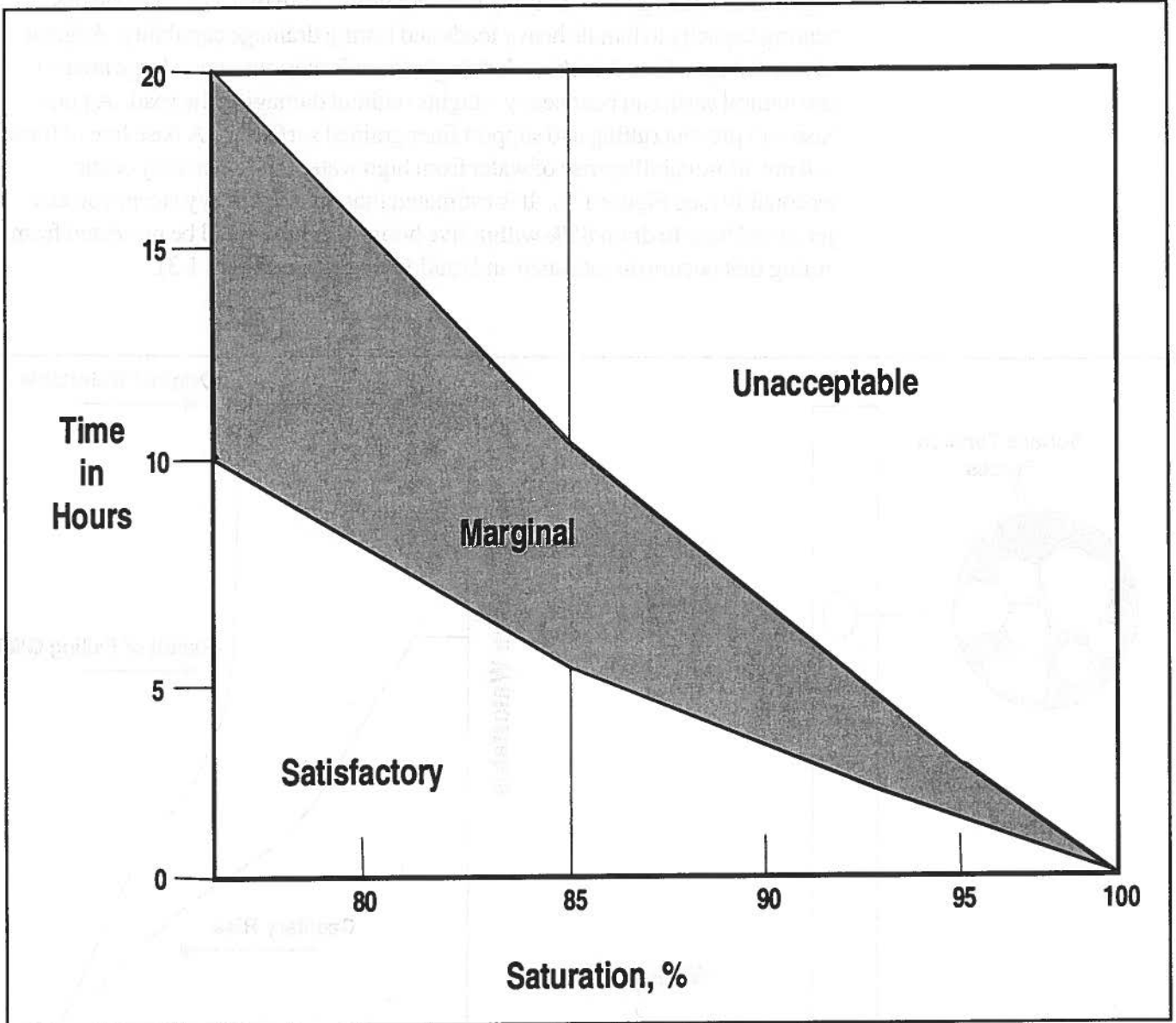

Figure 1.3- Moisture in Roadbase (NHI Course Pavement Design, p.193)

### 1.3 Crowning

If you do not know what caused the pothole you fixed yesterday, you will fix it again tomorrow. The same applies to other types of road defects. There are many factors which cause defects in aggregate surfaced roads. Each factor contributes to a specific distress in gravel roads. Poor drainage and an improper ratio of fines to coarser aggregate are contributing factors in most types of defects.

One of the keys to maintaining a smooth road is drainage. Standing water causes road material to separate and creates potholes. The best way to drain a road is

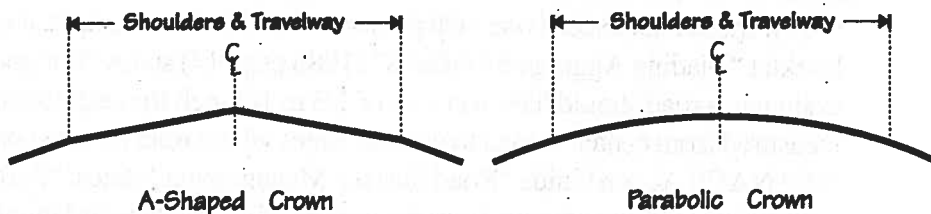

Figure 1.4-Road Crowns

by crowning it so the center of the road is higher than the shoulders. This can be done by cutting the crown into the road and by leaving more material in the center than on

the shoulders when spreading the material back onto the road. The crown should be an A-shaped crown, NOT a parabolic crown.

#### What is a crown?

A road must be bladed so that the center is higher than the edges to allow water to drain into ditches as quickly as possible. That is accomplished by blading a crown on the road.

- Keeping a crown on the road is probably the most important part of blading because lack of a crown causes trapped water to break up the crust, producing potholes, washboards, and an overall rough road.
- The amount of crown is the amount of slope on the road. For good drainage, a road should have a crown of 1/3 to 3/4 inch for each foot of width measured from center of road to outside edges where road meets shoulder.

The most desirable crown is shaped like the letter A; in other words: a straight, sloped line from the center of the road down to the edge of the shoulder. The A-type crown is hard to maintain because motorists tend to drive down the middle of an aggregate surfaced road, straddling the crown. As traffic goes down the center of the road, it compacts the road surface on each side of the center line. Consequently, as you carry on your dragging operation, your cutting edge will wear faster in this harder, off-center area. This accounts for the moon-shaped wear in the cutting edge. The crown resulting from such a worn blade resembles an inverted letter U, or the shape of a parabola; thus, the term parabolic crown.

A bad feature of a parabolic crown is that it is relatively flat across the center of the road; it holds moisture longer and defeats the purpose of crown. When the roadbed is wet and ready for reshaping, you will be able (with new cutting edges) to rebuild the A-type crown.

The best way to ensure that a road has the proper crown is to use a crown gauge (slope meter) on the grader. The gauge or meter is attached to the grader to give a constant reading of the amount of crown as the road is being bladed.

### **Guidelines Needed for Road Crowns**

How much crown should an aggregate-surface road have? Written sources vary in their recommendations but seem to have led to a conclusion that the maximum crown should not exceed one inch per foot of width. For example, the NACE booklet "Blading Aggregate Surfaces" (1986 page 14) states "For good drainage, a road should have a crown of 1/3 to 1/2 inch for each foot of width measured from center of road to outside edges where road meets shoulder." The 1992 NACE Action Guide "Road Surface Management" states: "the degree of crown is the amount of slope from the middle of the road toward the shoulder. Good drainage requires a crown of 1/2 to 3/4 inch for each foot of width, measured from the center of the roadway to the outside edge." For many roads, a crown of 1/2 inch per foot is insufficient to carry water rapidly off the road. This is especially true if the road is on a grade or if the surface is of average or greater roughness. The AASHTO Maintenance Manual (1976) suggests a crown of 1/2 inch to one inch per foot for earth-aggregate surfaces (see Sections 2.300 and 2.560).

Like every aspect of design or maintenance, this issue has arisen in a number of tort liability cases. In several, a plaintiff has alleged that there was insufficient crown. Generally, the crown was about 1/4 inch per foot in these cases in the location affecting an accident. At least one case has been litigated based in part on a plaintiff's allegation that a crown of 3/4 inch per foot is excessive.

From reading a number of their depositions it is clear that most grader operators are aware of the need for an appropriate crown. However, few seem to have any specific value in mind. Although most roads seem to end up with enough crown, thanks to the skill, experience, and good judgment of the grader operators, a more definitive answer than "enough" would be better when a grader operator is asked how much crown a road should have. It is suggested that jurisdictions having responsibility for aggregate-surface roads establish guidelines for the amount of the crown.

In northern climates, the most desirable crown might vary from season to season. The maximum crown might be used in the spring when runoff from snow melt and spring rains present the greatest problems of surface drainage. A lesser crown

might be more appropriate in the winter when ice on the road is likely to be of greater concern than running water.

In any case, some guidelines are better than none to help prevent the occurrence of the road without crown. A road with insufficient crown will be a liability problem when it is the location of an accident.

In most cases, crowning will adequately drain a road surface. The wider the driving surface, the more difficult it is to keep the crown in a road. A heavily traveled road will usually become very wide, especially near intersections where there is a lot of stop-and-go traffic. This particular stretch of road will be extremely difficult to maintain. A hard packing type of material should be used in these areas if at all possible.

Ideally, potholes should be cut all the way to the bottom. This can rarely be done, and if the road is already low in the center, can create a "canal effect" that may be very difficult to fill. Since most of the holes will be in the center portion of the road, it is usually only possible to cut off the high spots and fill the holes with material gathered from cutting the shoulders. Since loose, dry material won't compact in the center of the road to help create a crown, any rebuilding or reshaping of a road top must be done with an adequate amount of moisture present. In problem areas, the use of a water truck may be necessary. With the proper amount of moisture, the material will pack in the holes without beating out. With too much moisture, the material gets splashed out of the holes by traffic.

#### **1.4**

##### **Ditches**

Motorgrader operation for cutting a new ditch are covered in section 3.1. Periodic maintenance of these ditches is required to remove debris that will prevent free draining of the ditch. Excess material (sand, silt, and clay) that has migrated from the roadway may also be retrieved and remixed on the road surface.

Cleaning or pulling ditches typically involves using a motorgrader unless the slopes are too soft to support the grader, the slopes are too steep for easy access, or the ditch is frequently interrupted by drain pipes or culverts. Another problem in some areas of the country is limited right-of-way. Boom-mounted articulated buckets, such as Gradalls, are more appropriate in these exceptional cases.

The grader's moldboard is positioned to remove collected road gravel and fines, vegetation, and debris from the ditch as it reshapes the ditch's cross section to the correct slopes and depth. Where vegetation is heavy, an initial pass by the grader may first be needed to clear it. Or, indeed, mowing or other vegetation removal operations may be called for first. While moist gravel and fines should be recovered from ditches and moved back onto the traveled way to be

incorporated in the surface course, mud or other undesirable material should never be placed on the traveled way (Problems Associated with Gravel Roads-FHWA, # FHWA-SA-98-045).

It's important to create a smooth flow line for water to move unimpeded through the ditch. In the process, the ditch's full capacity to carry drainage is restored. One hazard for which grader operators must be alert is large solid objects in ditches; boulders, rock outcrops, stumps, and other just-under-the-surface objects that can severely damage the moldboard, the grader itself, and its operator. Ditch cleaning combines with smoothing and reshaping operations to provide for uninterrupted drainage across the roadway crown and shoulders, and into the ditches. Also associated with ditch cleaning is the cleaning out of culverts and drains, although the grader is of little use in these activities.

### 1.5

#### Culverts

Hydrology and Hydraulic Design are topics which could require lengthy explanations. In order to simplify replacing a culvert, many equipment operators just replace the culvert that washed out with one "the next size bigger." More precise

<b>SIZE &amp; CAPACITY OF PIPE CORRUGATED STEEL PIPE</b>			
<b><u>Arch Pipe</u></b>	<b><u>Round</u></b>	<b><u>Cap .05% Slope In Miners Inches</u></b>	<b><u>Cubic Feet per Second (CFS)</u></b>
	12"	68	1.7
18" x 11"	15"	120	3
22" x 13"	18"	196	4.9
25" x 16"	21"	300	7.5
29" x 18"	24"	400	10
36" x 22"	30"	760	19
43" x 27"	36"	1240	31
50" x 31"	42"	1840	46
58" x 36"	48"	2720	68
65" x 40"	54"	3600	90
72" x 44"	60"	4800	120

1 CFS = 40 Miners Inches = 449 gpm

Table 1.1 - Capacity of Steel Pipes

methods of placing new culverts or replacing old ones are shown in "NACE Action Guide Drainage." The section on Hydrology explains the rational method  $Q=CiA$  (pages 3-8) that yields the volume of water a culvert needs to carry. If the volume in cubic feet per second (CFS) is known, a culvert may be sized using the Hydraulic Design method explained in the NACE Action Guide. A simplified estimate can be made using Table 1.1. It should be noted that these capacities are estimates only based on a .05% slope.

After sizing a culvert, proper placement of the culvert needs to be insured.

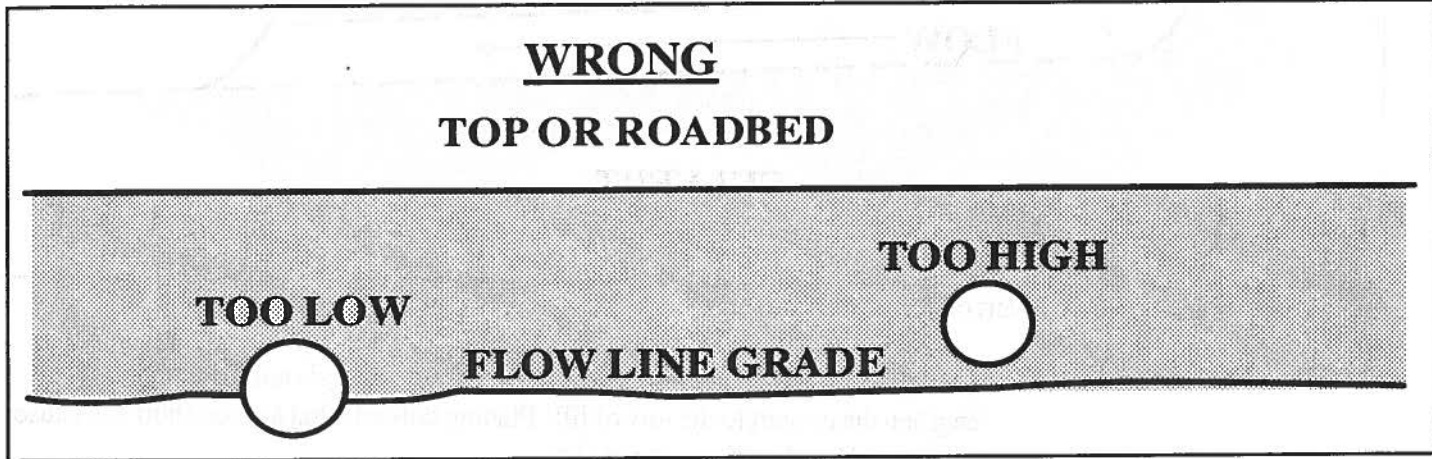

Figure 1.5 - Improper Culvert Installation

Care should be taken to carefully match the inlet and the outlet elevations. Streams naturally correct any changes to bed elevation. The results of improper installation could be devastating to a stream channel or wash out a culvert.

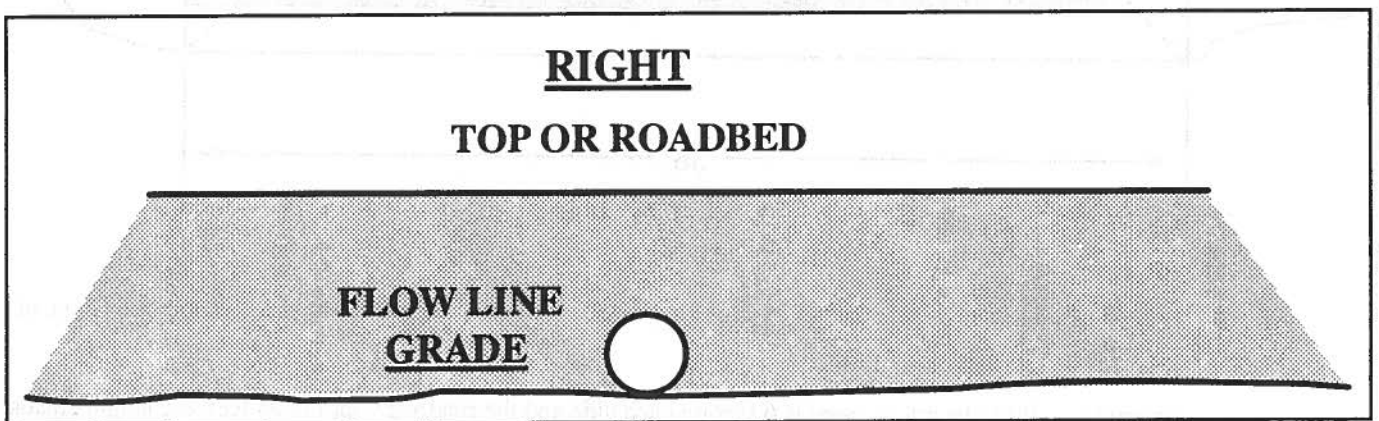

Figure 1.6 - Proper Culvert Installation

Installing a culvert at flow line will avoid silt accumulating in culvert or erosion around outlet.



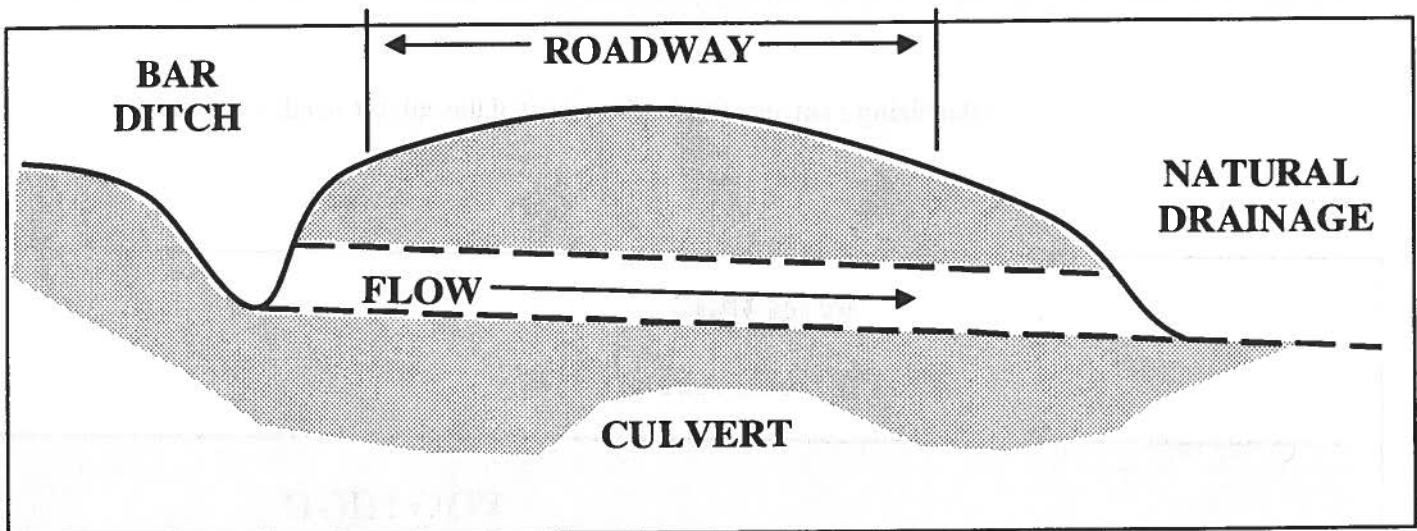

Figure 1.7 - Placement of Culvert on Natural Drainage

In some locations where a steep drainage occurs, care should be taken to lengthen the culvert to the top of fill. Placing culverts that are too short can cause erosion and head cutting around pipes.

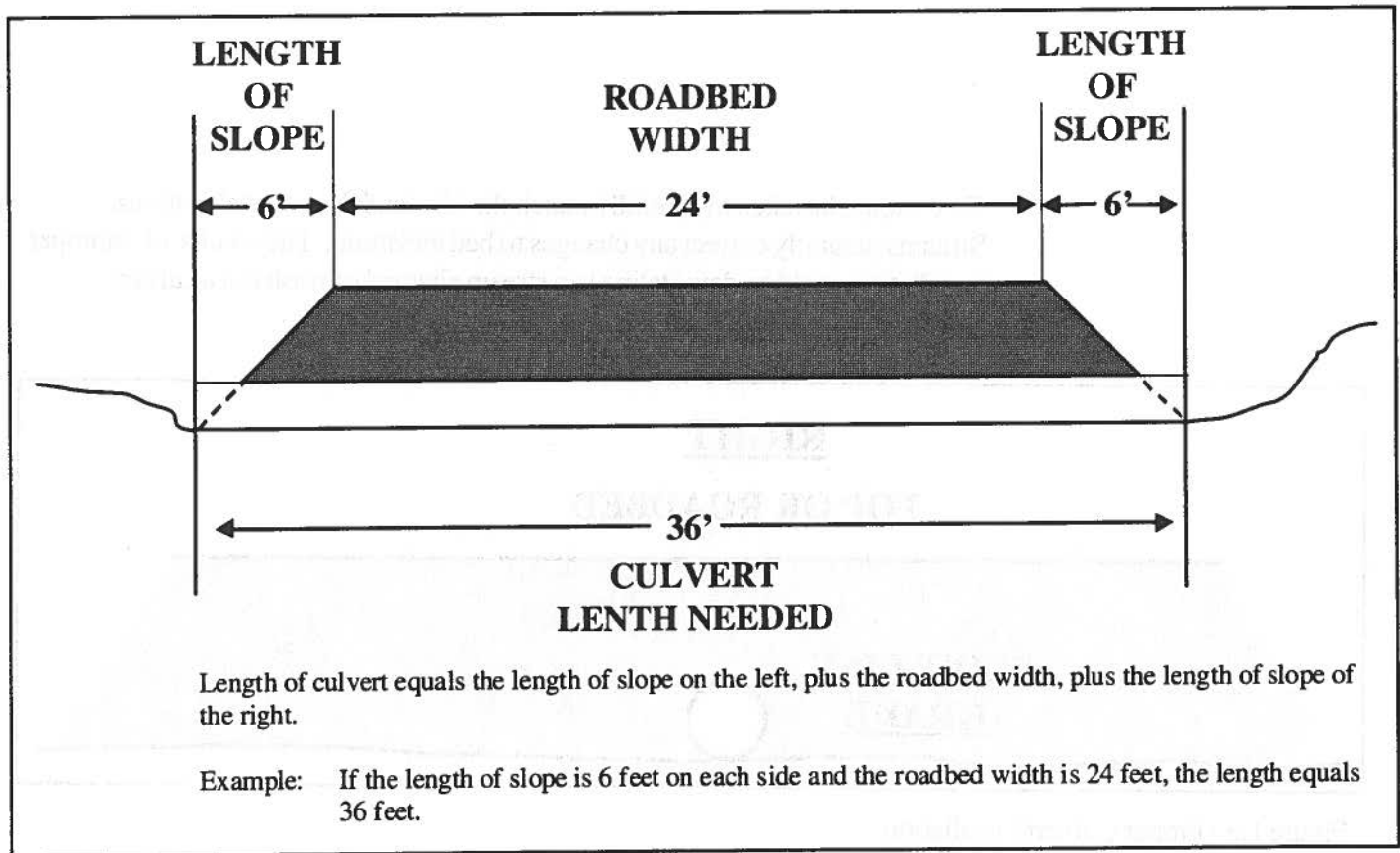

Figure 1.8- Proper Culvert Length Needed

This drawing shows how to estimate the proper length of culvert that is needed to match a drainage.

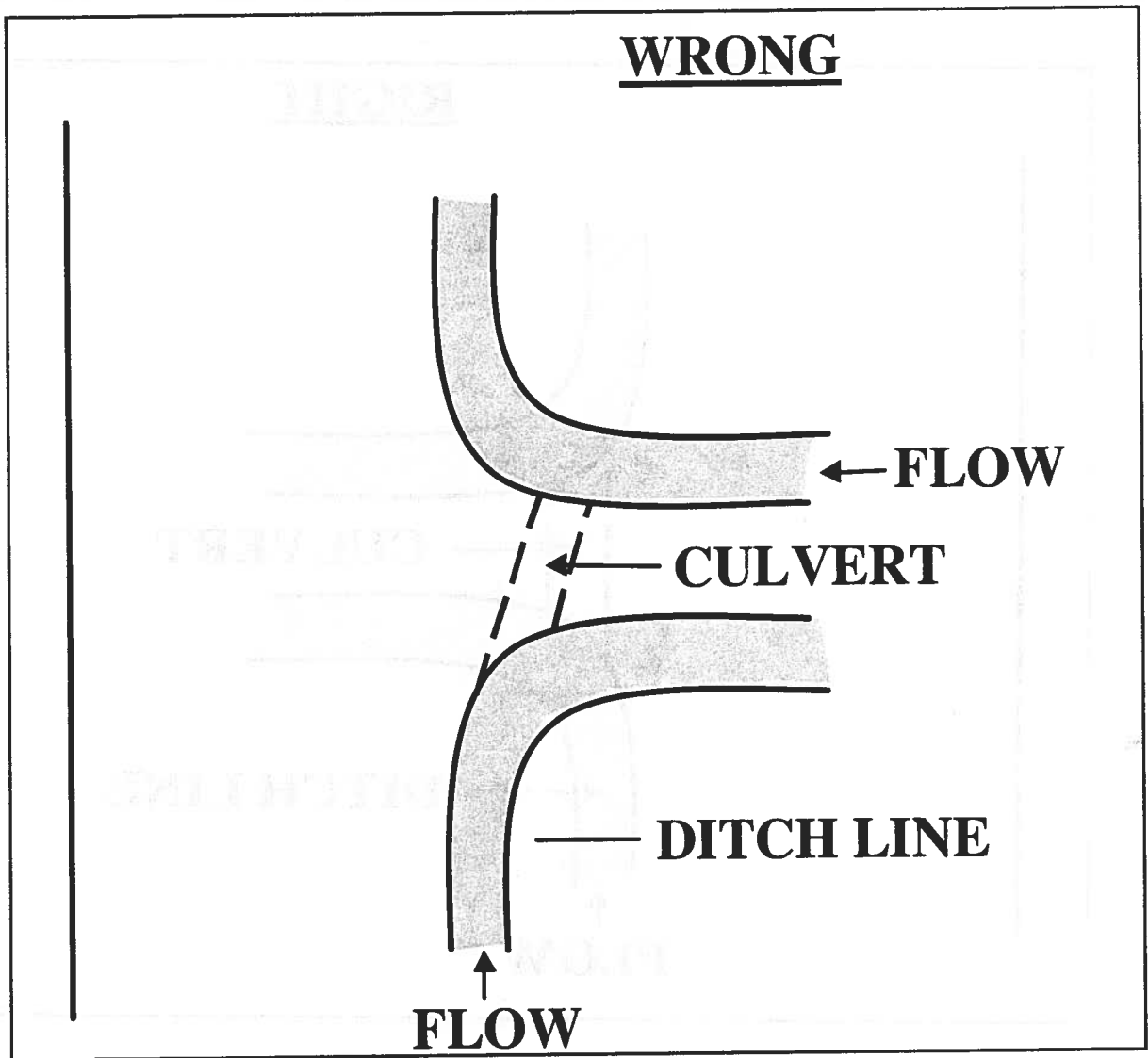

Figure 1.9 - Poor Culvert Placement Under Intersecting Road.

The culvert shown above is placed improperly. As water exists this pipe water will erode the opposite bank.

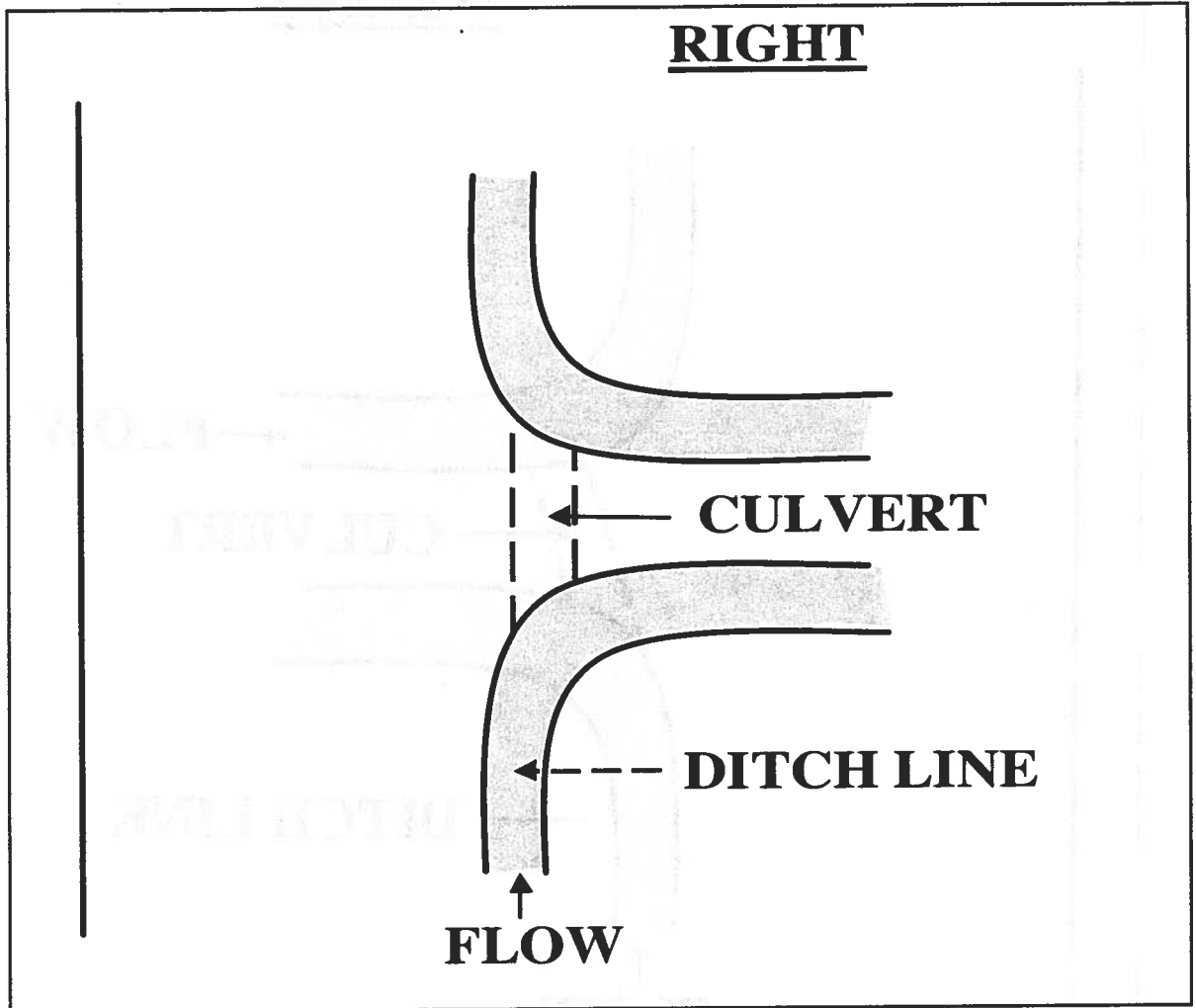

Figure 1.10 - Proper Culvert Placement Under Intersecting Road.

The proper length of pipe was selected for the following conditions. This installation will prevent erosion of opposite ditch.

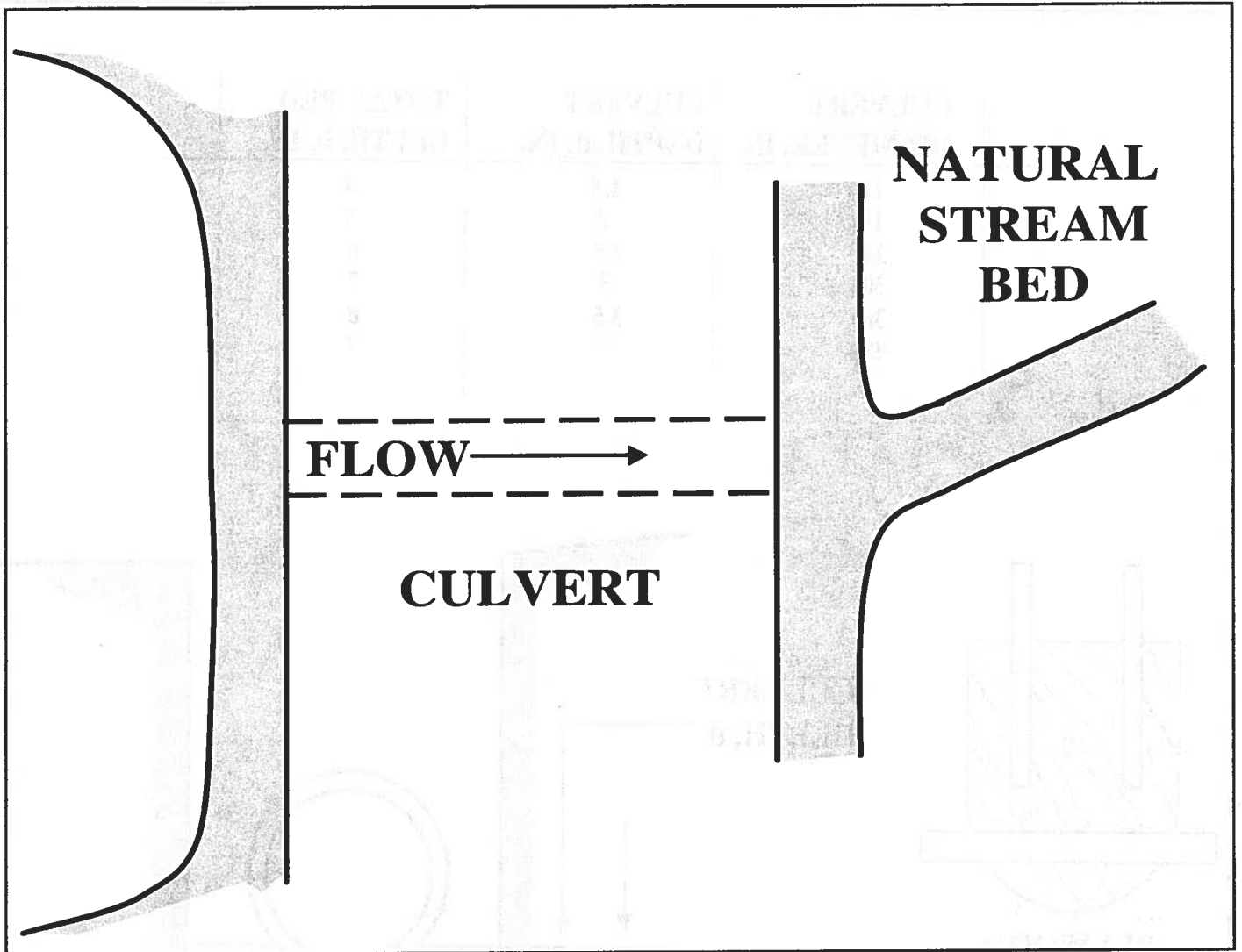

Figure 1.11 - Using Natural Stream Bed as Drainage Outfall

Culverts should be placed as close to a natural stream bed as possible. As water exits this pipe, erosion is prevented by allowing water to flow in existing natural stream bed.

CULVERT DIAMETER, IN.	CULVERT DEPTH, d, IN.	TOTAL BED DEPTH, b, IN.
12	1.5	4
18	2	5
24	2.5	6
30	3	7
36	3.5	8
48	5	9

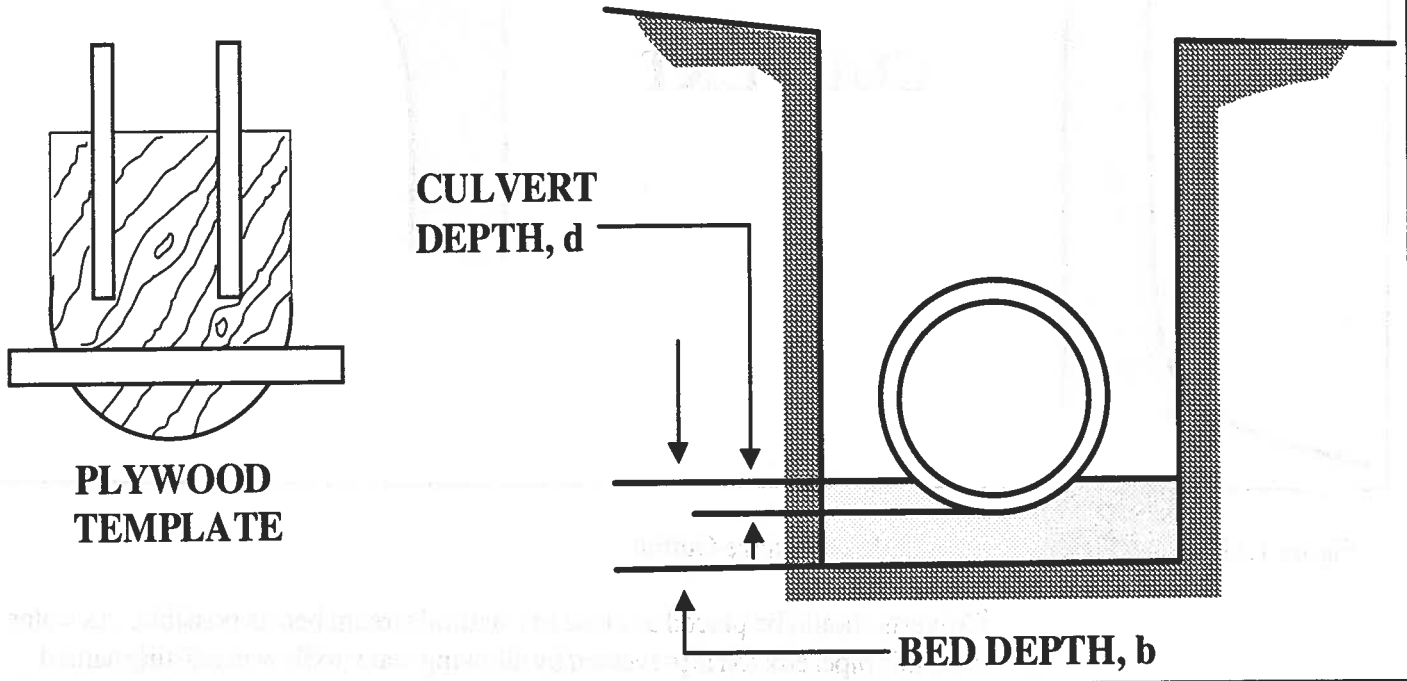

Figure 1.12 - Culvert Bedding

The use of bedding material free from rocks, insures that the culvert will remain strong and round while culvert is being placed and for many years in the future.

When trenching is needed to install a culvert, a trench should be wide enough to allow workers to compact material placed around the pipe.

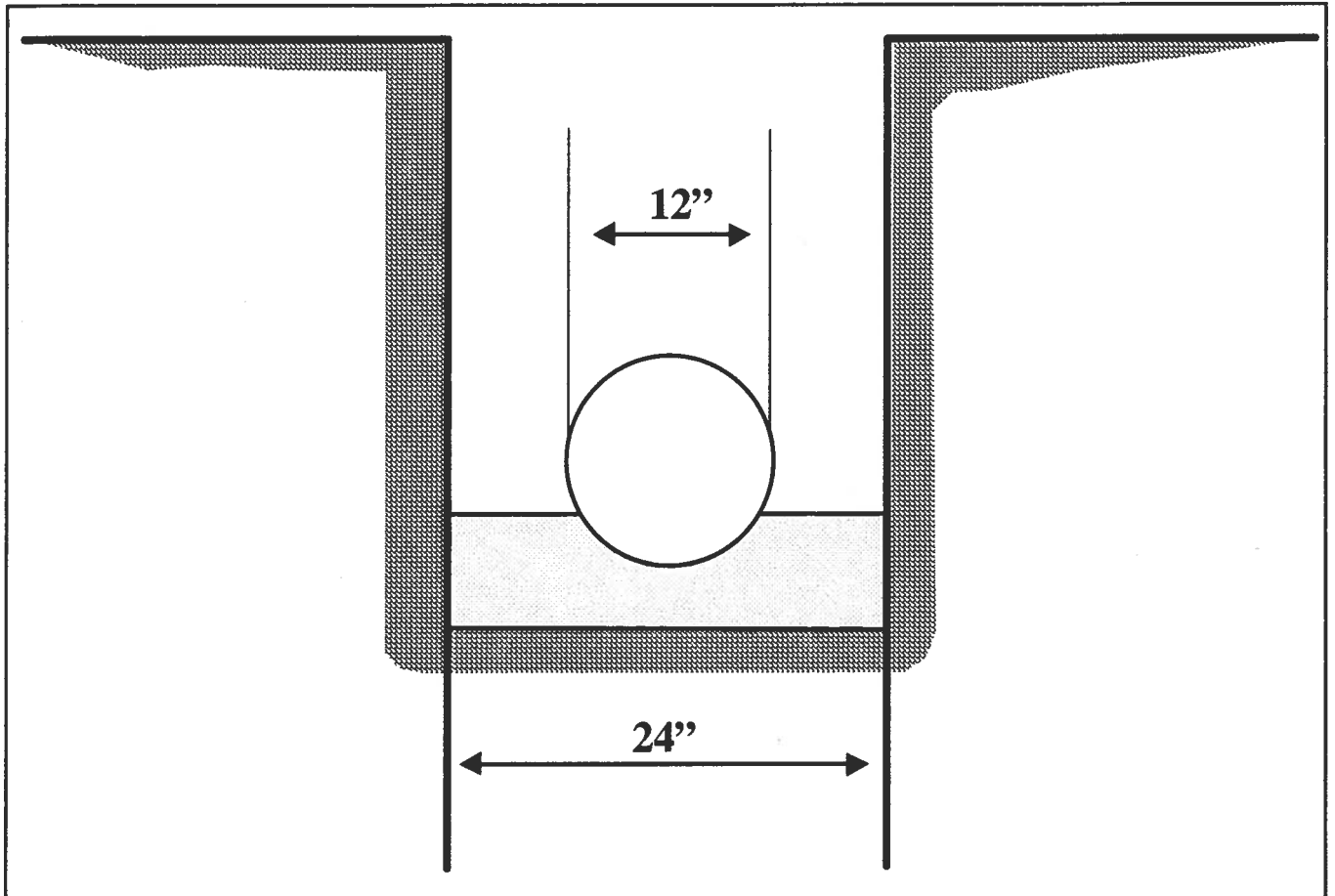

Figure 1.13 - Trench Width

Proper drainage really is the key to maintenance of roads. If water is allowed to run off the roadway, out of the road base, and away from the road prism, the road will remain in good shape.





# Chapter 2

## Materials

### 2.1

#### Introduction

The motor grader operator designs and shapes the roadway with each maintenance pass. The shape and composition of the roadway affects how the public drives. A more consistent surface of the roadway will encourage better driving habits.

**Wheel Paths:** Four wheel paths instead of just two or three means that the center of the road will receive half of the traffic and hence will last twice as long. When both directions of travel use the center wheel path, the crown will rapidly deteriorate. The goal in maintenance this is to encourage the public to stay on their own side of the road.

**Centerline:** the operator must keep the center of the road in the center of the roadway. Each final layout pass must be uniform and placed so that the driver will not have to adjust to a different center line frequently.

**Cross Slope:** A consistent crown allows the driver to maintain position on the road without adjusting the steering wheel to the new cross slope each time it is changed. A well-trained operator will maintain a uniform cross slope and may choose to use a slopometer to achieve this end.

**Consistent Edges:** Edges must be parallel to the centerline and of uniform elevation. Edge drop offs encourage the driver to migrate to the center of the roadway.

**Other factors:** There are other factors that affect driver performance. Improperly maintained driveways, intersections, large rocks, irrigation ditches, parked cars, windrows, etc. will all cause the driver to shift toward centerline. (Ideas from W.F. Heiden.)

**Clearzones:** AASHTO Standards for Low Volume roads recommends that a ten foot clear zone be established on each side of the road for safety. This allows errant motorists to take corrective actions before impacting a fixed object. Another benefit of this practice is that drivers aren't intimidated by roadside objects such as trees, vegetation, utility poles, fences, mailboxes etc. and stay on their own side of the road.

## 2.2

### Profile-Cross Section

#### Why aren't our county roads in better shape?

The public and public officials in some locations in Montana ask this question with good reason. The only season some of these roads are in excellent shape is in the dead of winter when they are frozen solid. This article is an attempt to explain what is wrong, and surprisingly, some of the things the traveling public can do to help.

Many of the gravel roads in Montana were built long ago. Some of them have poor foundations that were not intended to carry today's traffic. Some of them have alignment problems creating safety hazards. The road surfaces on poorly aligned curves are extremely difficult to maintain, because the fast moving vehicles tend to throw the gravel into the ditch. To have an understanding of what is going on with a particular road, one has to have some idea of how roads in general are built and maintained.

The composition and life of a gravel road is not overly complicated. Assume that we are talking about a road that is in reasonably good shape. It has at least the minimum 60 foot required right-of-way. It has ditches on both sides that are adequate for drainage and snow removal. There are no soft spots in the base. No irrigation water is allowed to run in the ditch, and the road has a proper graveled surface.

There should be four to six inches of surface material containing all sizes of angular, not rounded, material from small particles of clay binder up to 3/4 inch stone. This material may be extremely difficult to find in some areas of Montana. The surface layer locks together (not possible when using round stone) forming a thick crust that helps support vehicles and sheds water. There should be a crown in the road and no vegetation on the roadway surface. This will allow water to run freely to the ditch and not puddle in the roadway causing potholes.

Now if you have less than the above, you are probably riding on a very rough road. But don't lose heart. Despite the fact that counties have more miles of road to maintain than they have money for, they do have a plan for rehabilitating about twenty miles of worn out road a year. County officials are constantly working with the public in many ways to economically improve the road system, including establishing gravel pits and obtaining right of way. They monitor their budgets closely to purchase the minimum equipment necessary for road rehabilitation. This includes graders, dump trucks, grid rollers, and a water truck.

The best time (or only time) to reshape a gravel road is when it has moisture in it. The moisture helps bond the particles, aiding their compaction into a dense mass. The surface forms into a thick crust that will repel rain. Once the dry weather comes and the road sets up, the road work is done for the year (unless you have a water truck and want to work in dry weather). Attempts at grading a dry road

cuts the peaks into the valleys of washboards. This looks nice and smooth, but the next vehicle that passes kicks the fines out again. In most cases you are better off not grading a dry road.

### What can be done to help preserve a reshaped road?

**Keep down the speed!** Vehicles at high speeds unravel the very top of the road. This causes dust. Losing the dust (fines) allows the coarser stones to become easily dislodged. Gravel roads lose about an inch of surface material every year. This amounts to about 500 tons per mile. Dust is a safety hazard and detrimental to crops. As the roads wear down, the lost material must be replaced at public expense.

**Don't drive in the same track!** Almost everyone has a tendency to drive right down the centerline, flattening the crown, and causing wheel ruts. Drive on the right side of the road. This is especially important right after the road has been graded and it is still compacting under wheel loads. If traffic would slow down and help compact the whole road, it would last longer.

**Don't overload a vehicle!** This will cause a road to rapidly deteriorate. An overloaded grain or logging truck will cause particles to grind together, breaking them up and creating more dust and fines. If there is already a weak foundation, it will push the road into it.

Once you have approximately 100 vehicles per day (some say less), a gravel road is almost impossible to maintain. This is true even if you have the best materials and design. Then it requires constant grading and the addition of water or chemicals to control dust and provide for stabilization.

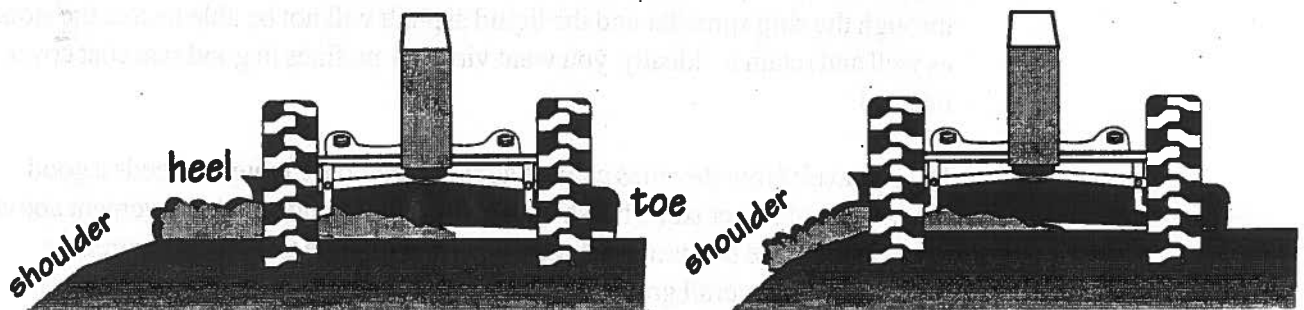

Figure 2.1 - Edge of Road Maintenance

## 2.3

### Benefits of Testing Aggregate, Ken Skorseth, Field Coordinator, SD LTAP Overview:

When county roads or bridges are constructed with Federal or State funds, there are virtually always plans and specifications prepared for each project.

Aggregate specifications are established for base materials, asphalt or concrete material and even for surface treatment cover aggregate. When material is produced for these jobs, aggregate testing is done and testing is also done at the time of construction. But, when maintenance work is done on the same roads, there is generally precious little testing done. When small construction or rehabilitation projects are done with local funding, again, there is generally very

little testing done. Is this wise? We often use local sources of gravel that local managers are quite familiar with. It is great to have general knowledge of local sources. We will be taking a risk in many situations by not taking at least a random sampling of material and testing it. Pits and quarries can change as material is removed over the years.

#### **Value of testing:**

**Surface Gravel:** Even material used for a gravel road should have some testing done on it. One of the biggest problems in surface gravel can be the problem with washboarding. This problem has more than one cause, but the primary cause is poor gradation of gravel. Good surface gravel should have topsized stone no larger than  $\frac{3}{4}$ " or certainly no larger than 1". It should also have a good percentage of true fines meaning material that passes a #200 sieve. The ideal percent of fines should run somewhere between 7 and 12% of the total sample passing the #200 sieve. In addition to this, a test for liquid limit and plasticity is very valuable to determine whether the gravel will have a good "binding" characteristic. This is of great value to know whether the gravel will stay in place on the road. Surface gravel that lacks plasticity will constantly loosen under traffic and will require much more frequent blade maintenance as well as being prone to washboarding.

**Seal Coat Cover Material:** Close control of top size is very important here. You will have complaints of cracked windshield if you don't watch this. Generally, a top size of  $\frac{1}{2}$ " or less is recommended, depending on the type and quantity of liquid asphalt used. Also, the overall gradation of cover aggregate is very important. If the percentage of fines gets too high, the material will be hard to get through the chip spreader and the liquid asphalt will not be able to coat the stone as well and retain it. Ideally, you want virtually no fines in good seal coat cover material.

**Base Gravel:** Now the rules change again. Good base material needs a good percentage of larger stone for strength to carry the loads on the pavement above it. And the stone needs a good percentage of fracture to help get aggregate interlock. The overall gradation is important also. There needs to be a good blend of sand sized particles and some fines along with the stone to get good density. But a highly plastic base material is never good. This will cause the base to hold moisture and it will lose its strength, especially during the spring thaw season. "Heaving" problems will become much worse as well. But the biggest problem will be early failure of the pavement surface because of weak base. Good base needs to drain well.

**In summary, there is not a "one size fits all" gravel.** Different uses require different types of material and only by testing can you really determine if it's suitable for a specific purpose. Testing prior to use solves many problems that can show up later – even on a common gravel road. It pays to increase your knowledge of materials and testing.

## 2.4

### Gradation

All roads, even those that carry small amounts of traffic, should be built of materials and soils that will make them passable in all kinds of weather.

The soils used in road building differ. They may swell when wet, may break into fine pieces under heavy traffic, or may be so hard they are nearly unworkable.

Coarse soils or mineral particles are called **aggregates**. Those that are very hard and not easily broken up are best to use for road surfaces and shoulders. The main types of aggregates are as follows.

- Crushed stone – made by breaking or crushing rock, usually limestone.
- Gravel and natural sands – usually found in river beds or as natural deposits in old stream beds.
- Slag – a by-product of iron and steel manufacturing.
- Burnt clay or expanded shale – a by-product of heavy industry or commercially produced as aggregate material.

### Blending Aggregates

The proper blend of different size aggregates on a road produces a surface that can be used in all types of weather. An aggregate surface is most economical for roads carrying low volumes of traffic because materials are usually available locally.

Figure 2.2 - Uniform Material

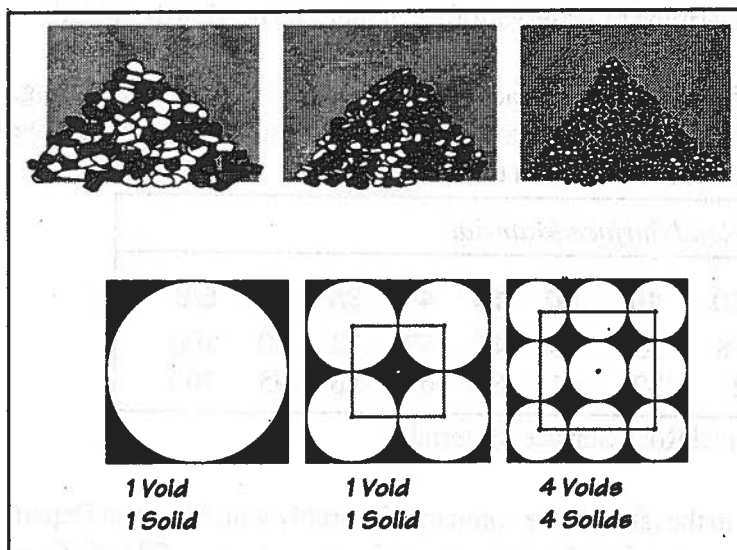

To make a wearing surface, different size aggregates are blended together and spread across the road base. The largest size is usually no more than one inch. Blending different sizes allows the pieces to lock and pack (compact) together to make a strong, tight surface.

Fine material (fines) is added to a mixture of different size aggregates to fill the small spaces (voids) between the pieces. Fine material, often called binder or mineral filler, is a very important part of the mixture because when water is added, it acts like cement to hold the aggregate together. Without enough fines, moist aggregate will not dry to form a hard-wearing surface. Dust

blowing from an aggregate surface indicates that fines are blowing away.

The addition of material is usually accompanied by blading and grading, although light applications of medium-sized and fine aggregates may be made occasionally to correct slippery conditions. When increasing the depth of the surface, filling

depressions, restoring crown and profile, or correcting other problems that require coarse aggregates, well-graded aggregate mix should be dumped in windrows for spreading by a motor grader along the area to be repaired. Well-graded aggregates should have a maximum size of approximately one inch with approximately 10 to 25 percent passing a number 200 sieve. Fine aggregates needed to correct ravelling, and in some cases corrugations, are usually obtained by blading material from the shoulders and ditch lines. Fine aggregates can also be hauled and spread in a manner similar to coarse aggregates.

### Surface Stabilization

There is general agreement that a majority of gravel road surfacings will be improved by stabilization. If you can eliminate a reshaping job and a couple of smoothing jobs you can save a lot on maintenance.

Some surfacings are unstable because certain rock sizes are missing from the gradation. To provide a stable surface the missing sizes need to be blended into the existing surfacing during reshaping activities.

Two reshaping activities should be scheduled to complete the process. The first reshaping allows collecting samples for analysis. The second reshaping is when missing sizes are incorporated.

Depending on the degree of sophistication in your department it may not be possible to determine missing sizes by sieve analysis. In this case an experienced supervisor can determine by observation what material needs to be added.

The most common gravel road surface defects; potholes and puddles, rutting, dust, surface softening, and corrugation; stem from the quality of surface material, level of maintenance, and amount of traffic.

<i>Recommended Gradation for Gravel Road Surface Material</i>									
<b>US Standard Sieve Size</b>	<b>200</b>	<b>80</b>	<b>40</b>	<b>20</b>	<b>10</b>	<b>4</b>	<b>3/8</b>	<b>1/2</b>	<b>5/8</b>
Percent Range From:	12	18	25	33	43	57	72	80	100
To:	16	24	32	41	52	69	86	95	100

Table 2.1 - Recommended Gradation for Gravel Road Surface Material

The information in the table above compares favorably with Montana Department of Highways (MDOH) *Standard Specifications*, Section 701.02, Crushed Top Surfacing Type "B", Grade 3, page 519, 1987 Edition.

## Gravel Road Maintenance Innovations: Selection of Material for Gravel Roads

The best material for gravel roads should have the following elements.

- Have sufficient amount of fine material that will pass through a 200-mesh sieve (i.e. silt and clay components). The recommended amount is that 12% to 16% pass through a 200-mesh sieve.
- Follow and stay within the gradation curve limits shown in Table 2.1.
- When reshaping and leveling use a maximum grain size that doesn't exceed 16 mm (0.63 in.).

In practice, the surface material often exceeds the particle size limits of sand-sized material. This should be avoided because an excess of the sand fraction reduces the stability of the surface material.

The ideal gradation can be easily obtained by two-phase crushing — using a jaw crusher and a cone crusher — of a rock or coarse gravel raw material. The crushed material should follow the upper of the two particle size limits.

For the best results, a gravel road surface using natural material should be a mixture of two fractions. To achieve the necessary density, smoothness, and water resistance, there has to be a clay material; the use of a coarse material is necessary for the stability and wear resistance of the layer. The amounts of clay and coarse material required are determined by doing a sieve analysis of the existing road surface material and from the material proportions calculating the amounts of new material. Because traffic tends to wear and break down the road surface material, the new material should follow the upper, or coarser, of the two particle size limits. Table 2.2 (page 25) shows how much crushed material should be added yearly.

### 2.5 Moisture Content

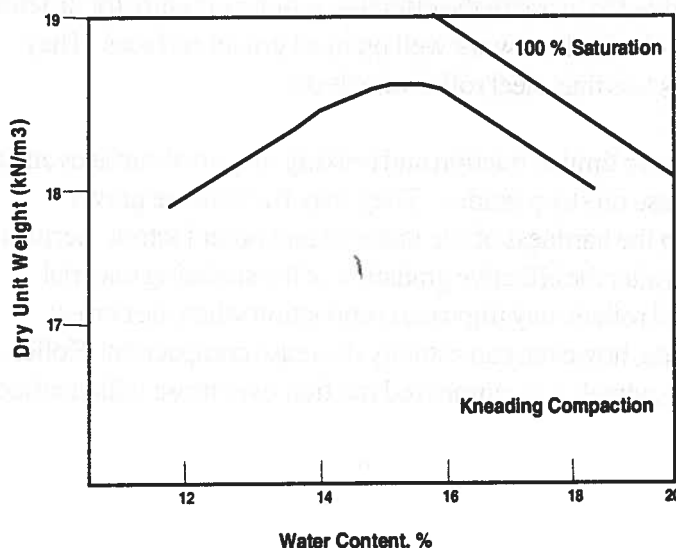

Moisture content of soils is very important to consider when compacting a road base or reworking and compacting the surface material. Figure 2.3 shows the results of a “Standard Proctor” compaction test. This test provides a standard effort of compaction to a soil sample to see what density can be achieved at varying percent water content. As water is added, increasing the moisture content to 12, 14, and 15 percent, the density increases. If more water is added, density decreases, water replaces solid material and the material becomes too wet to work.

Figure 2.3 - Moisture Content vs. Overall Density



## 2.6

### Compactive Effort

Compacting granular soils increases the ability to bear weight and will make unpaved roads hold together much longer. Density of granular soil will increase as water content is increased until all of the voids are filled with water. Granular soils are improved with compactive effort and large amounts of water (Fundamentals of Geotechnical Analysis p 314-315).

Fine grained soils are best compacted on the dry side of the curve. Clays will assume a flocculated structure if not worked when wet and have better weight bearing capacity. Good judgement will allow the operator to know when the best time to work a soil will be. As a rule of thumb-when a handful of material is squeezed, and a ball is formed that doesn't stick to the fingers, you may have the right moisture content.

Compaction is most easily obtained using a rubber tire roller. Rollers that attach to the rear of the grader work well. A separate tire roller is best.

### Rollers

Compaction rollers are common pieces of road construction and maintenance equipment. However, they are probably not used as much as they should be in repairing and maintaining gravel roads. In compacting a gravel surface, the aggregate particles are worked closer together, reducing the air pockets and producing a denser, stronger mass of material.

Pneumatic-tired, steel-wheeled, and (sometimes) vibratory steel-wheeled rollers are appropriate for compacting gravel roads. All should be self propelled. Towed rollers are not recommended because they normally exceed the braking power of the towing vehicle and are also very tough on the towing vehicle's final drive. The rubber tire inflations of pneumatic-tire rollers can be varied from high pressure for greater compaction to lower pressure for reduced compaction. Ballast is sometimes added to increase the effective ground pressure for different conditions. Pneumatic-tired rollers work well on most gravel surfaces. They fracture gravel particles less than steel roller wheels do.

Steel-wheeled rollers have limited traction and braking on gravel surfaces and are not recommended for use on steep grades. They may fracture the gravel particles, depending on the hardness of the material and other factors. Serious fracturing of gravel can alter the effective gradation of the surfacing material. Vibratory steel-wheeled rollers may improve compaction when the correct frequency and amplitude, however, can actually decrease compaction. Rollers with rubber-tired drive wheels have improved traction over those with dual steel drums.

For spot corrections on gravel roads, small compactors, including nonself-propelled ones, will greatly improve the quality and durability of the repair. A variety of power trammers and vibratory plate compactors are available.

Smooth drum rollers are used most often for finishing operations, on fills, or in highway construction. They are not suitable for producing uniform compaction in deep layers and, when used on cohesive soils, they may produce a density stratification with high densities at the surface of each layer. The action produced by the pneumatic-tired roller is somewhat better than the smooth drum roller in that it produces a combination of pressure and kneading action on the soil. Rubber tire rollers are effective for a wide range of soils from clean sand to silty clay (Problems Associated with Gravel Roads, 5-26-27.)

## 2.7

### Vegetation

Much of the surfacing material lost from the road remains near and can be retrieved and reworked into the surface. Gravel and sand that work down into the subgrade will hopefully contribute to the bearing strength of the roadway. The majority of the fines that leave the roadway in the form of dust remain close by on the shoulder in the ditch or on the backslope. The amount that settles up to fifty feet away may be too difficult to retrieve and could have been kept on the roadway with dust treatment. Sand and gravel that is pushed off the roadway generally stays on the shoulder or migrates toward the ditch, can be retrieved and re-mixed to form excellent surfacing material. The problem that many counties are confronted with is that vegetation grows in this material and it is difficult to separate from the gravel, sand and fines.

Many counties have effective methods of retrieving this material and dealing with vegetation. Commercial products similar to a tilling disk have been used with success. Some counties have developed this type of equipment independently. Bob Montgomery of Judith Basin County has used a method for several years that minimizes vegetation problems and equipment use to just the motor grader and moldboard. If vegetation is heavy and if pulling the shoulder of the road all at once will disrupt traffic, the operator will pull only half of the shoulder and work a windrow of vegetation and material on the shoulder out of traveled way. The vegetation is then allowed to dry and the material is spread back across the roadway. The rest of the shoulder is then retrieved and vegetation allowed to dry before reworking the material into the surface. This process is then repeated on the opposite side of the road.

Each jurisdiction will have to decide if there is sufficient room on the roadway to allow vegetation to dry and if the driving public will tolerate this practice. The benefits of improved drainage and reduced cost for addition of new gravel

outweigh the inconvenience. Eventually new gravel will have to be considered.

Oversized rock and loose vegetation should be sorted out of the road material and dumped in the borrow pit. A rock rake may be needed to help sort excess rock. Any material that must be wasted into the borrow pit should be feathered so as not to create a hazard for mowers or snow plows.

The grass and weeds growing along the edge of a road can cause many problems. On a narrow, low volume road, tall grass may cause drivers to confine their driving to the center of the road. This will make the road even narrower and may become dangerous. If this grass is pulled in with the gravel during grading, it can be difficult to separate. Early mowing will help, but there always seems to be some vegetation to deal with when grading a road.

It is harder to separate grass from gravel in wet conditions than when both are dry. If there is a lot of grass on a fairly narrow road, it may be wise to wait for dry conditions before grading. If the road must be graded while wet, it might be best to stay out of the grass as much as possible.

If vegetation is still a problem, here are a few things to try.

- Run a very slow square blade while spreading.
- Make extra passes while spreading to help separate the grass.
- If the machine has a moldboard tilt, try tilting the blade forward to create more of a dragging action. If the grass happens to spread out without bunching up, it can be left on the road and traffic will beat it out.
- If the grass and weeds cannot be separated easily, a stack may have to be left on the shoulder and worked out after it dries.

In dry conditions, the technique is much the same. When the grass breaks up and spreads out on the road with the gravel, it may look a little ragged, but the traffic will pack the gravel and disperse the grass and weeds.

Problems often occur when the vegetation bunches up and drags under the blade, leaving ruts and furrows. With a slow or square blade, the ruts will run more across the line of traffic, making a much rougher driving surface. Sometimes the operator may have to leave the long parallel ruts just to get rid of the grass. Grass and sod growing off the road and on the end slope add strength.

## 2.7

### **Oversize Rock**

Usually, when a road is graded, the blade will pick up a lot of large rock from the shoulder. This rock is called "oversize". It can be a problem and a nuisance just like vegetation, but there are several ways of dealing with it. If the operator has a lot of material to work with, he may want to leave some of the smaller oversize

on the road. If there is enough material to leave 2 inches on the road, then any rock under 2 inches can be left. If there is adequate moisture in the material, the 2-inch rock should compact with the road material and not become a problem. Any rock that the operator doesn't want left on the road can be sorted out and dumped into the borrow pit.

Many of the same techniques that are used to sort vegetation can be used to sort oversized rock; however, more than the usual number of passes may be required. The blade should be set very sharp so that no oversize is left on the road along with the road material. After each pass, there will be more and more oversize in the windrow. When there is mostly oversize in the windrow, and with the windrow close to the shoulder, the blade should be set at a slow or straight angle and the rock should be pushed off the road as far as possible. If a square or straight blade is used to sort oversize, some of the larger rock will spill out the toe of the blade. An extra pass may be necessary to push these rocks off the road. Many times when sorting oversize, rocks will hang up under the blade and make ruts in the road. When there are rocks dragging under the blade, the blade will often bounce over these rocks and leave a pile of material in the road. This can be picked up in a later pass. There is no way to get all the oversize off the road and any rocks left will separate from the road material and be whipped off the road by traffic. If there is too much oversize left on the road, a rock rake may be needed to finish the job. Any stack of oversize left on the shoulder should then be bladed into the borrow pit.

## 2.9

### New Gravel

When new crushed gravel is hauled onto a road, the grader operator has several factors to consider.

- The project must be properly signed to prevent anyone from driving into the stacks of material.
- If the trucks should dump on the left side of the road as they are traveling, so the drivers can line up with the shoulder of the road, use a flagman to avoid head-on collisions.
- The trucks should have spreader chains set to spread the gravel to the desired length.
- On a road with heavy traffic, the operator may have to windrow the gravel after every round of trucks have dumped.

To windrow the gravel, set a sharp blade and heel the gravel toward the shoulder on which it is dumped. It may take a few passes to push the material into a windrow. Leave about a tire width between the windrow and the edge of the shoulder.

To lay out the windrow, set a medium blade and, using the toe, take about 6 inches or so of material out of the stack. The first pass will fill in any holes or dips in the road. Leave a stack with the heel but don't worry if it isn't uniform. After several passes the material will even out.

Always be aware of trying to stay level with the grader while pulling material from the stack. If the machine doesn't feel level, adjust the controls for the next pass, and try to level the road.

AVERAGE DAILY TRAFFIC	Crushed Gravel yd <sup>3</sup> /mi	
	WIDTH OF THE ROAD	
	20 Feet	23 Feet
500-1,500	104	122
200-500	67	78
100-200	37	43
-100	25	28

Take only as much material with each pass as the machine will comfortably handle. It will take several passes to lay out the windrow.

When the last of the windrow has been pulled out, there should be several small windrows across the road. While keeping a level blade, bring these into one windrow and leave it about a foot from the shoulder. Turn the machine around and set a square blade with the toe well outside the front tire and the heel just outside the rear tire.

Table 2.2 - Quantity of New Gravel

Lean the front wheels toward the windrow to allow more reach with the toe of the blade. If the stack is small, take it all in one pass. The gravel will slough out the toe end of the blade and fill the space between the windrow and the shoulder.

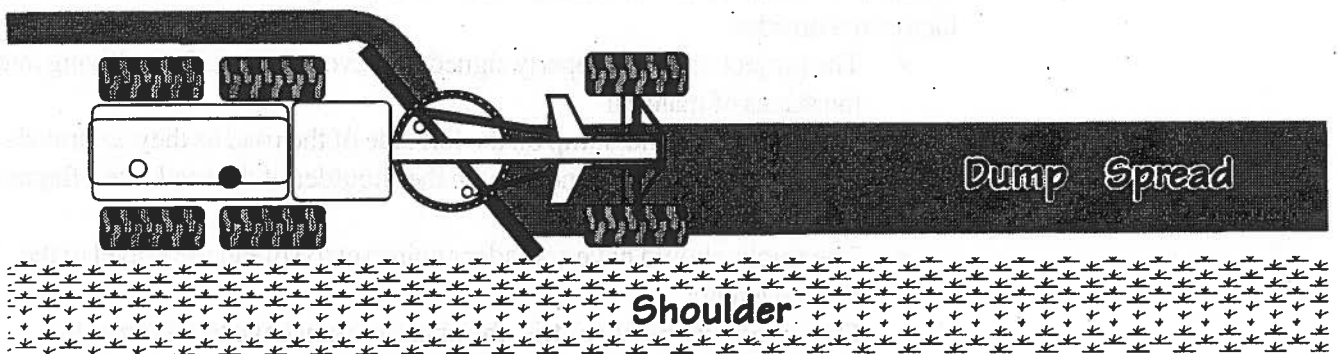

Figure 2.4-Spreading of New Gravel

If the stack is too big, take two or more passes.

Once all the material is off the shoulders, there should be a small windrow of gravel left. Use this to finish the shoulders and to fill any low spots with a slow square blade.

## 2.10

## Cost Comparison - Paved vs. Unpaved Roads

**Nelson Road**

Cost for 1 mile gravel and 1 mile paved

Cost on a 10 year time line

Road has 225 ADTs

*Gravel*

	<b>Cost/year</b>
<b><u>Grade 5 times/yr</u></b>	<b><u>\$490.00</u></b>
Mowing	\$50.00
Miscellaneous	\$200.00
New Gravel Once Every 7-10 yrs - 3 in lift (Cost/year)	\$910.00
Snow Plowing (10 times/year)	\$500.00
<b>Total</b>	<b>\$2150.00/year</b>

**Other Cost Information**

- Grader \$49.00/hr
- Snow Plow \$42.00/hr
- ¾ gravel in place \$7.75

*Paved*

	<b>Cost/year</b>
Snow Plowing <b><u>(20 times/year)</u></b>	<b><u>\$882.00</u></b>
Mowing	\$50.00
Miscellaneous	\$300.00
1 ½ in Overlay every 10 years/mile	\$3200.00*
Stripping	\$150.00
<b>Total</b>	<b>\$4582.00/year*</b>

\*If chip sealing, not overlaying cost is \$1800.00/year for a total cost of \$3182.00.





## Chapter 3

# Proper Blading Techniques

### 3.1

#### Ditching

The first thing to do when cutting a ditch is to lay out a line. This can be marked with stakes visible from the cab to assist with cutting it straight. When you are ready to start, angle the blade sharply and place the toe or leading edge of the blade behind the front wheel. Set the toe tight and raise the heel up (Figure 3.1). Drive the machine down the row of stakes taking a cut of 1" or 2" in depth. This is called a **marker pass** and will help to keep the ditch straight. Do not make this cut so deep that you have trouble steering the motor grader. (*Don't get greedy!*)

Figure 3.1- Marker Pass

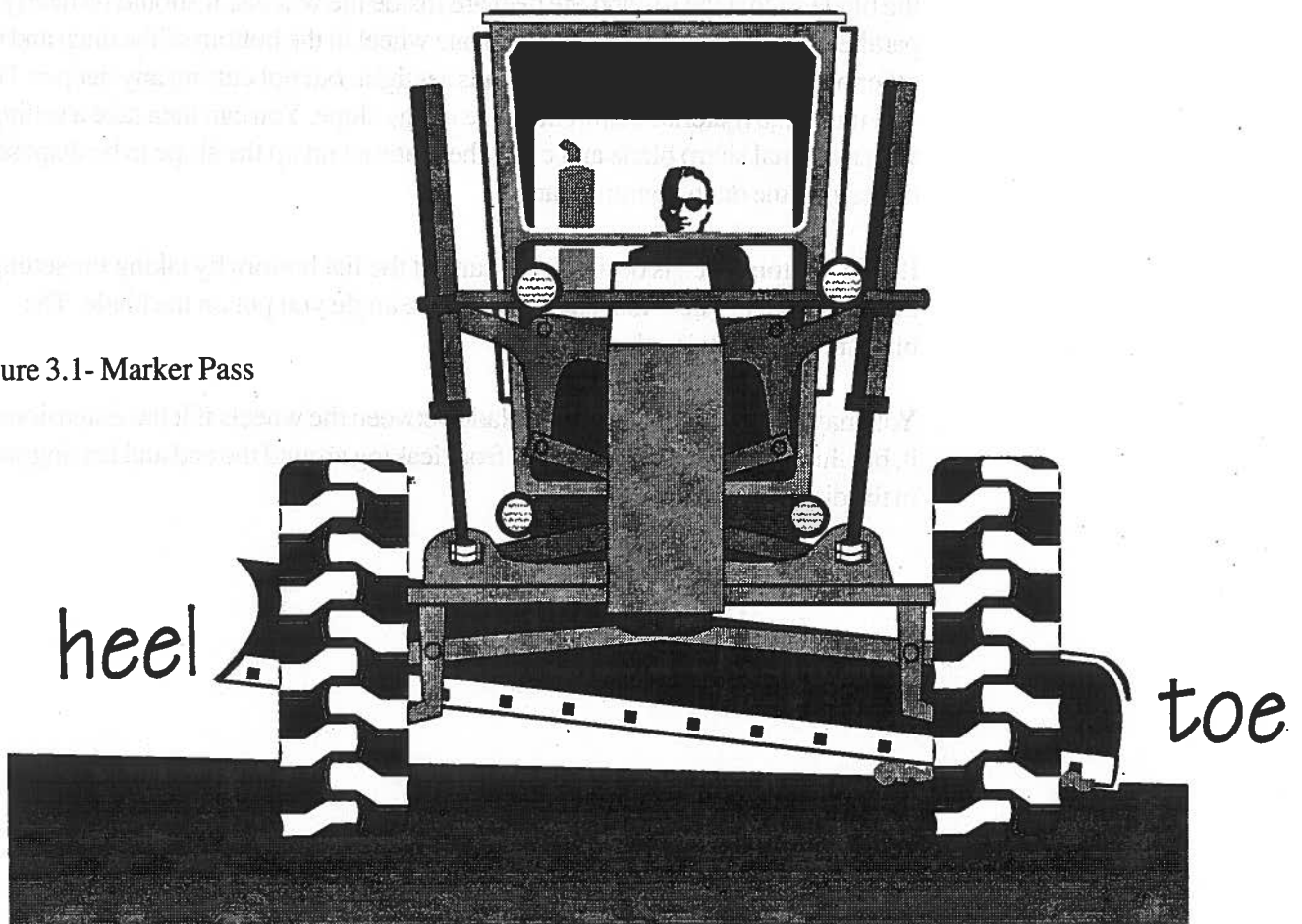

The next pass should be made with the same setting, but place the front wheel in the marker cut and put a load on the machine. Again, do not take more than the machine can handle. Put the motor grader in first gear and do not go too fast in case you hit a hidden rock. These settings will deliver the windrow under the grader and you will get better traction because you are not on loose material.

The next pass, set the blade tight on both ends to deliver the material outside of the wheels. Next set the machine straddling the windrow and carry the windrow away from the ditch bank. ***Always be sure to move the windrow before it becomes so large that it is awkward to handle.*** If the ditch still needs to be deeper, repeat the steps as outlined except the marker pass. Normally when cleaning a ditch, the marker pass will not be necessary.

If a back slope is required, place one set of wheels in the ditch bottom and the other outside the ditch. Put the heel down with just enough angle to deliver the windrow outside of the wheels; put the toe down enough to cut the slope desired.

To clean the windrow out of the ditch without leaving anything in the bottom, set the blade so that the toe and the heel are inside the wheels. It should be nearly parallel with the machine. Drive with one wheel in the bottom of the ditch and the other on the first slope. Have both ends set tight, but not cutting any deeper. This will move the material a short distance up the slope. You can then take a setting with a normal sharp blade and carry the material on up the slope to be disposed of, leaving the ditch bottom clean.

If a flat bottom ditch is desired, you can cut the flat bottom by taking the setting outlined above. The width can be set by the angle you put on the blade. The blade must also be leveled.

You may have trouble getting the blade between the wheels if it has extensions on it, but this setting prevents material from leaking around the end and leaving some in the ditch bottom.

### 3.2

#### Two Pass Maintenance-Smoothing (Dragging) Gravel Roads

To keep a road in good condition, the road surface and shoulders must be maintained. The surface of the road is smoothed by dragging. Smoothing should be done when there is moisture in the road. It is uneconomical to smooth a dry road because material loosened by the smoothing will blow away.

Properly blended aggregate and fines will dry to form a hard crust that provides a wearing surface. The crust will carry traffic until it breaks; it also sheds water to keep the base stable. To keep the crust intact, put only enough pressure on the blade to smooth surface and drag excess material across the surface. Additional material may be added to keep the crust intact.

Eventually traffic and climatic conditions will completely break down the crust and the road will need reshaping.

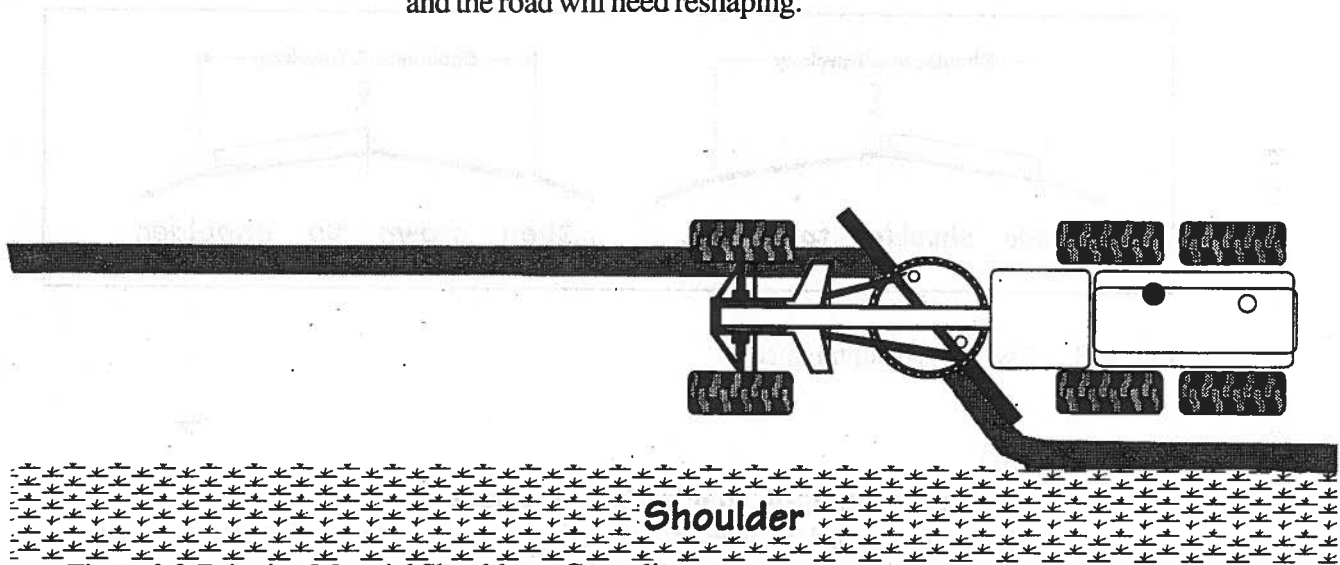

Figure 3.2-Bringing Material Shoulder to Centerline

Smoothing is limited to leveling the road surface when it becomes rough and uneven. The intent is to keep the stable crust, not to destroy it by cutting into it. Smoothing can be done by drags, rakes, and underbody blades. Here we will discuss smoothing with a motor grader. A dragging, rolling action created by the curve of the grader's moldboard helps compact the road surface as it is bladed. Blading speed will depend on the grader, pressure of tires, and condition of the road surface. Going too fast will cause the grader to bounce, making it impossible to do a good job.

#### To drag the road surface:

- Check grader blade (cutting edge) to make sure it is in good condition.
- Shift moldboard so end of blade is at edge of road and at beginning of

shoulder.

- Tilt moldboard forward to get a dragging rather than cutting action.
- Angle moldboard at about  $30^\circ$  to  $45^\circ$  to spread loose material to center of the road.
- Lean or slightly tilt front wheels about  $10^\circ$  to  $15^\circ$  from the vertical in the direction aggregate rolls across blade.
- Periodically blade surface of the road against the flow of traffic to eliminate drifting of aggregate onto ends of bridges, culverts, intersections, and railroad crossings.
- Stop to repair minor bad spots such as holes, rutted areas and poor surface drainage conditions. Always have a shovel available.

Smoothing is normally done in two passes (one round) as shown in Figure 3.3.

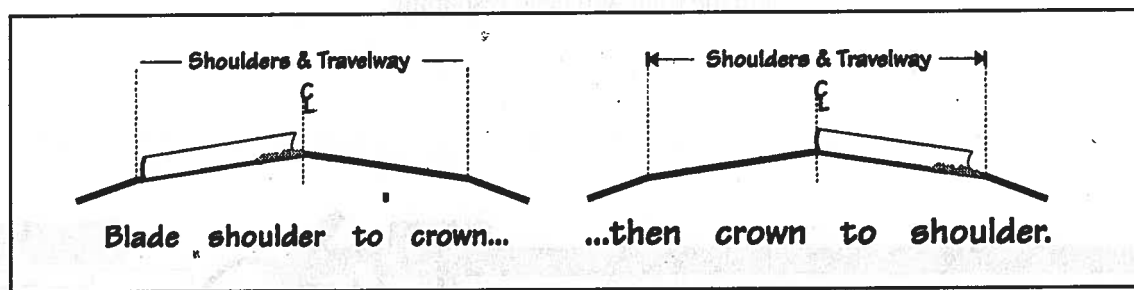

Figure 3.3- Two Pass Maintenance

### 3.3

#### Six Pass Blading-Reshaping Gravel Roads

Reshaping a road involves more than just smoothing the surface. Reshaping a gravel road requires cutting through the crust of the roadway to create a new smooth surface. Reshaping should be performed when the roadbed is moist, as a dry hard surface is difficult to cut and can damage the blade. After a period of rainfall or slow-melting snow, traffic scatters the aggregate, flattens the crown, makes potholes and deep ruts in the road, and produces a rough surface with ridges that look like a washboard. These conditions cannot be corrected by just smoothing the surface — you must reshape the aggregate base.

Reshaping involves remixing the aggregate base to get a proper *blend* of fines and different size aggregates and blading this blended material into a properly crowned road surface. When remixing, you may need to add additional aggregates and fines to road surface and shoulders, particularly in rough spots or washed-out places.

The development and maintenance of a proper crust can bring great personal

satisfaction, since the quality of the crust and its length of useful life depend on the skill used in blending coarse and fine materials which, together with moisture, form the desired crust.

The art of proper blending is a cut-and-try proposition depending on types of materials at hand. Experience will provide know-how to determine the correct blend.

The crust that forms the old wearing surface is broken up during remixing, often with a scarifier. The scarifier is an attachment to the grader used when the crust is too hard to cut easily with the grader's blade.

After the aggregate base is remixed, it is bladed to obtain a smooth road surface with the proper crown. (A new set of cutting edges, of course, gives the best results.) Traffic will compact this base, and a crust will form to give a new smooth wearing surface.

### Reshaping procedures

As with smoothing, reshaping should be done when the aggregate is moist. If reshaping is done in dry weather, water must be added to the aggregate to make it moist.

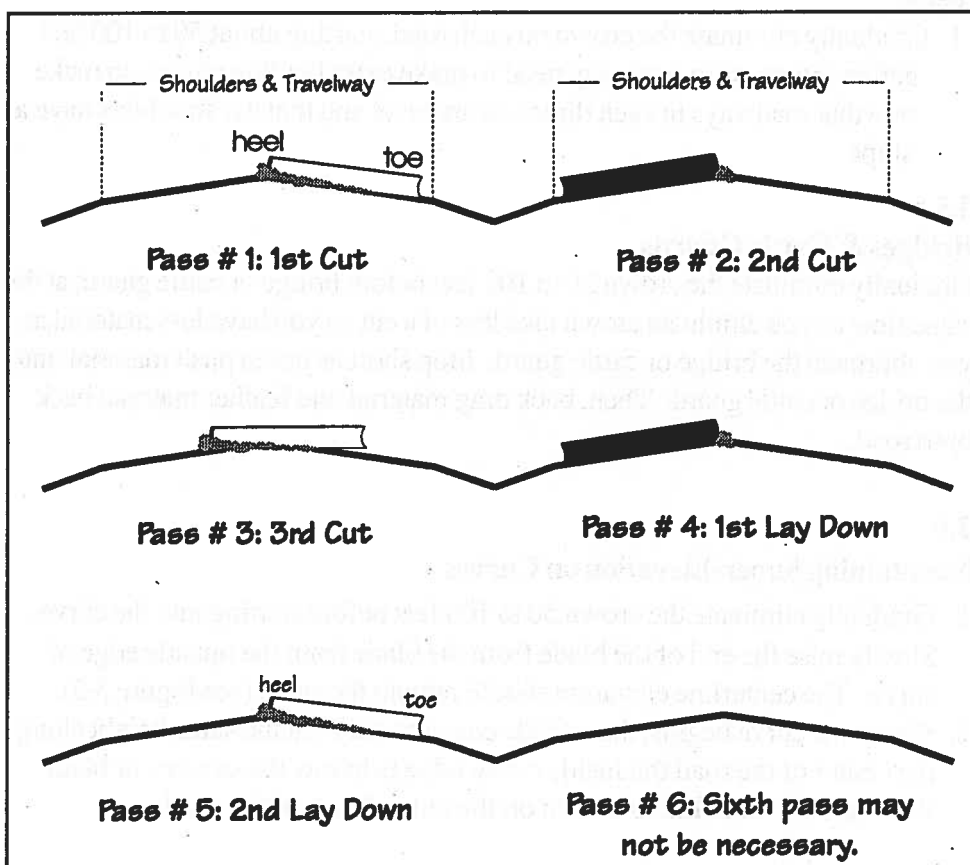

The blade is pitched slightly back to create a cutting action. The toe is placed at the edge of the shoulder, while the heel is at the center of the road. Lean the wheels  $10^{\circ}$  to  $15^{\circ}$  so the material is carried toward the center of the road and windrowed there. Proceed at 3-5 mph. Use enough downward force on the blade to cut to the bottom of potholes, washboarding and rutting in the roadway.

In case of deep potholes that cannot be repaired just by cutting, scarify the potholes at

Figure 3.4-Six Pass Maintenance Shaping a Road

least two to four inches below the bottom of the hole prior to reshaping.

On the second pass, spread the windrowed material back across the same side of the roadway, restoring the original crown and shape of the road.

Repeat this procedure on the opposite side of the roadway.

When you use rollers instead of traffic to compact a newly reshaped road, the extended life of the reshaping job will usually more than pay for the rolling costs.

### 3.4

#### Intersections

Use the following procedures when maintaining the intersection of gravel road and paved road.

1. Gradually eliminate the crown 50 to 100 feet before the intersection. At the point where the two roads meet, the grade should be the same.
2. Set the angle of the blade to meet the paved road, pull onto pavement, pull the aggregate off the paved road.
3. If there are large holes on the shoulder of gravel road, you may cross lanes to fill holes.

Use the following procedures when maintaining the intersection of two gravel roads.

1. Gradually eliminate the crown on each road, starting about 50 to 100 feet before intersection, you may need to make extra blading passes, to make sure that roadways in each direction are level and that the shoulders have a slope.

### 3.5

#### Bridges & Cattle Guards

Gradually eliminate the crown 50 to 100 feet before bridge or cattle guard, at the same time as you eliminate crown take less of a cut so you have less material as you approach the bridge or cattle guard. Stop short as not to push material onto the bridge or cattle guard. Then, back drag material and feather material back onto road.

### 3.6

#### Maintaining Super-Elevation on Curves

1. Gradually eliminate the crown 50 to 100 feet before starting into the curve. Slowly raise the end of the blade from the blade from the outside edge of curve. The centerline elevation should remain the same (see Figure 3.5).
2. Where the curve begins, the outside edge should be at the same height along the center of the road the inside curve edge is below the center - or bend the road. Do not blade a crown on the curved part of the road.

3. Slope the shoulder to the super-elevated part of the road downward from the road edge to the ditch.
4. Gradually change the road surface back from super-elevation to crown.
5. If super-elevation is too great you will have to rework the curve. Start by working the high side first. But let the toe of the blade cut loose material only. Set the heel down to cut center of road. Then, coming back on the second pass cut more in center of road carving material to the low side taking out crown. Then grade again using the normal grading of curve.

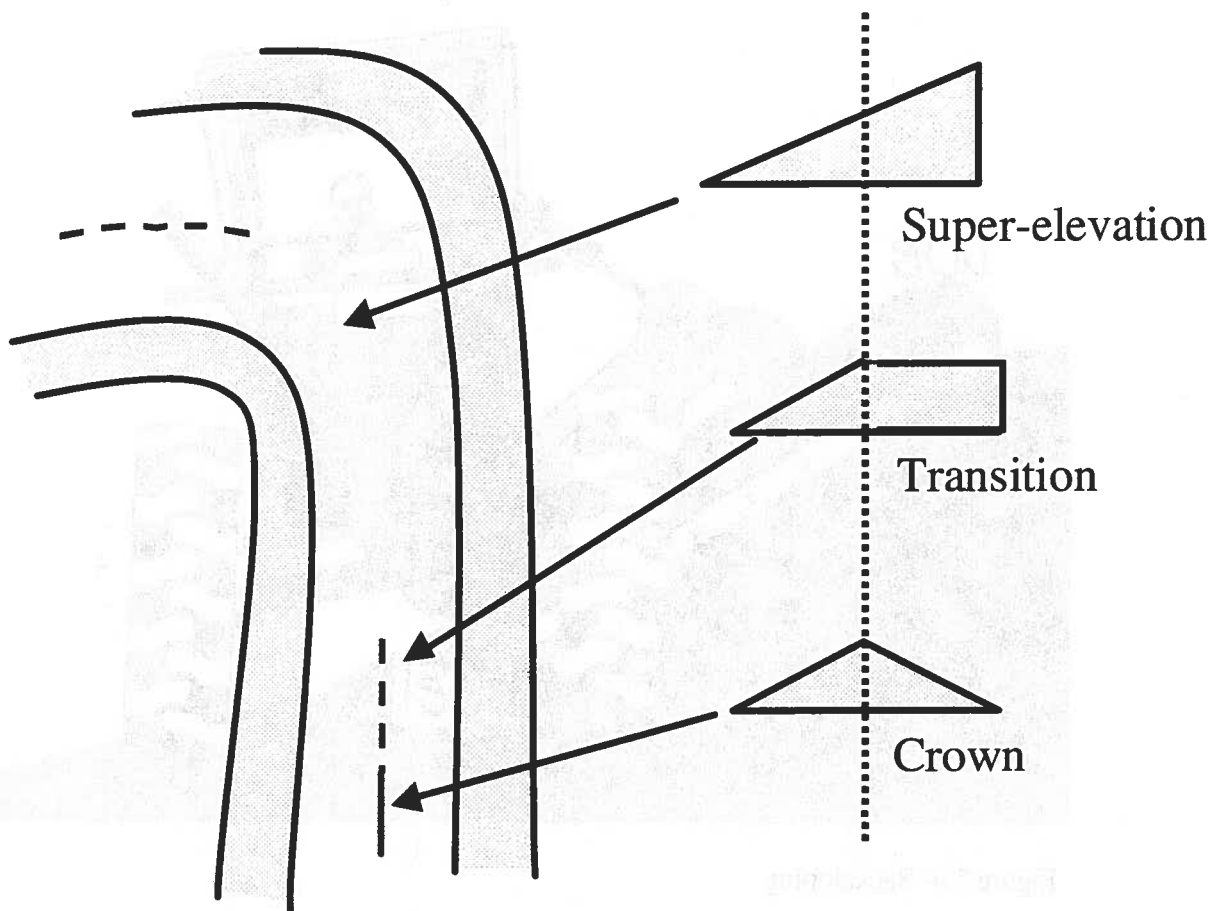

Figure 3.5-Super-elevation on Curves

### 3.7

#### **Backsloping**

Backslopes are only to be graded if there are loose rocks, or clods of dirt that may roll and cause a safety hazard. Other loose material that is brought off the slopes should be handled as outlined in ditch cleaning

Refer to the particular grader's operation manual for adjustment procedures for backsloping.

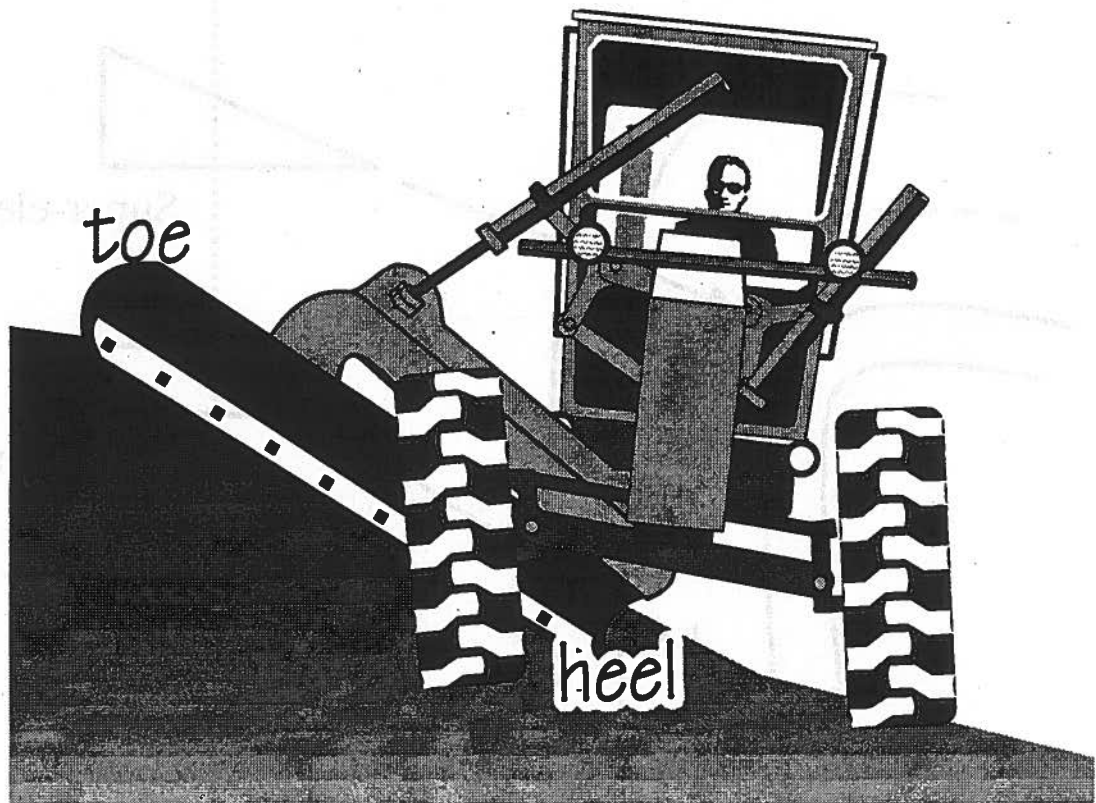

Figure 3.6- Backsloping

### 3.8

#### **Filter Fabrics: Installation of Geotextiles on Low Volume Roads**

This section provides the basic knowledge for the selection and installation of the proper geotextile and aggregates for use in eliminating perennial boggy spots and trouble areas.

Soil is the foundation material for all roads, whether in the form of native undisturbed subgrade materials, transported material or native embankment material. Vehicle loads are transmitted to the roadbed and if adequate support does not exist, severe rutting or washboarding will result.



In the fine-grained materials of Montana roadbeds, the stability is moisture dependent. In areas where there is poor drainage or subsurface water conditions, it is almost impossible to keep the roadway from rutting. Even though gravel is added to these locations, the roadway will produce ruts as soon as the next rainfall occurs. Placing a geotextile, or fabric as it is sometimes called, with four inches of gravel on these locations will eliminate the rutting and provide all weather service for the roadway. For vehicles weighing 60,000 - 80,000 pounds, the amount of gravel should be at least eight inches.

Table 3.1- Characteristics of Geotextile Materials for a Roadbed

**MINIMUM WEIGHT**

4 oz/square yard  
ASTM D 1910

**MINIMUM GRAB TENSILE**

90 pounds  
ASTM D 1682

**MINIMUM ELONGATION**

60% (at break)  
ASTM D 1682

**PUNCTURE STRENGTH**

30  
ASTM D 751

**EQUIVALENT OPENING**

60 minimum  
170 maximum

CORPS OF ENGINEERS  
CW-02215-77

(NOTE: if excessive vehicle weights or high volume/high velocity vehicle traffic is expected, the minimum values should be increased.)

**Selecting a Geotextile**

First, let's look at the two distinct types of fabrics available for roadway applications. The first type is the woven geotextile. This type resembles burlap in appearance in that the fibers are actually machine woven. Woven fabrics are very high in tensile strength properties; however, the properties of elongation and permeability are lower and these fabrics are not recommended for separation applications on low volume gravel surfaced roads.

The second type, and the type which is recommended for this particular application, are the *non-woven* fabrics. These fabrics are made from fibers placed in a random arrangement and bonded together by various processes such as needle-punched, spunbonded, melt bond, etc. These fabrics resemble the lining in the trunks of automobiles. Non-woven fabrics do not have the tensile strengths of the wovens but they have tremendous elongation and permeability properties which enable them to give excellent performance on the problem spots on low volume roads. The minimum requirements for a fabric to be used on a low volume gravel surfaced road are shown in Table 3.1.

**Site Preparation**

Ideally, the roadbed should be graded smooth and a crown established in the roadbed. If the roadway has deep ruts when placing the fabric and gravel, it will take additional gravel to fill the ruts adding to the cost of the operation. Second, and most important, a loaded dump truck, with its bed raised could tip over on its side if the rear wheels should fall off into the rut.

It is not mandatory to fully compact the section of roadway to be repaired prior to placing the fabric and gravel. In most cases, this would be very difficult to achieve, chiefly because this area is usually highly saturated with water. When the roadbed material is dry enough to hold up a motor grader and loose enough to fill in the ruts, use the motor grader to shape

the roadbed, filling in the ruts and establishing a crown.

In the case of an emergency or unusual condition such as a spring in the roadbed, it will not be possible to shape the roadbed. These conditions will be discussed later.

### Placing the Fabric

Once the roadbed has been shaped, the fabric can be rolled out. Since most manufacturers produce the textiles in roll widths of 12 ½ feet to 15 feet, it generally will take 2 rolls side by side to completely cover the roadbed. The first roll is lined up on one edge of the roadbed, starting about 20 feet away from the problem areas, and rolled out for about 20 feet. The second roll is lined up on the other edge of the roadway and overlaps the first roll near the centerline of the road. All overlaps should be a minimum of 12 inches whether they are on the centerline or where one roll stops and another begins.

Continue to roll the first roll out keeping about 20 feet ahead of the second roll. This will allow for periodic shifting of the rolls to keep the alignment correct. If conditions are windy when unrolling the fabric, the ends and sides will need to be weighted down to keep the fabric from blowing. This can be accomplished by putting shovel fulls of gravel or soil from the borrow ditch on the ends and sides to keep the fabric down. Depending on the velocity of the wind, a spacing of eight to ten feet is generally sufficient to keep the fabric weighted down. It is recommended to place the first roll on the downwind side of the road. The second roll will overlap the first roll in the direction the wind is blowing, keeping the wind from picking up the edge of the first roll near the centerline.

When the two rolls are rolled out and additional rolls need to be placed, fold the ends of the first two rolls back over on top of themselves about two feet. Start the additional rolls in the same manner as the first rolls with the ends next to the folds of the first rolls. As soon as the additional rolls are rolled out a short distance, pull the folded fabric over the ends of the additional rolls. Continue lapping the fabric in the same direction each time new rolls are placed. ***This is necessary as the gravel must be spread in the same direction the fabric is lapped.*** If the fabric has folds in it, flatten the folds in the same direction the fabric is lapped and weight the folds down as flat as possible.

The type of gravel to be placed on the fabric will chiefly depend on the local sources available. A “crusher run” gravel is probably the most common type of gravel to use. The gravel should range in size from a maximum of ¾ to 1 ½ inches in diameter and have at least 10% fines or dust. This dust should not contain any significant amount of clay. The gravel should have angular sides as with crushed stone as opposed to a round river gravel. The ideal material would conform to the following specifications.

GRADATION REQUIREMENTS (Percent Passing)				
SIEVE SIZE (mm)	1 ½ in (37.5)	¾ in (19.0)	No. 4 (4.75)	No. 200 (0.075)
Percent Passing	100	90-100	30-85	10-25
Plasticity Index	6-15			
Liquid Limit	Not more than 35			

Table 3.2 - Material Placed on Geotextiles

### Placing the Gravel

As stated previously, the gravel must be spread in the same direction the fabric is lapped. Spreading the gravel into the lap can cause the fabric to separate resulting in unprotected spots in the roadbed. Once the roadbed has been shaped and the fabric rolled out over the problem area, the gravel trucks can dump the gravel.

The two most common operations will be using end dump or belly dump trucks. The end dump trucks can either dump the gravel while driving forward or they may back dump. An experienced driver can chain the tailgate and spread the gravel very close to the required thickness of four inches. This will save considerable time in the blading operation. The belly dump trucks will dump in windrows and the motor grader will pull the material from the windrows and blade the gravel across the fabric.

The truck drivers should be cautioned against sudden hard stops or takeoffs while the trucks are on the fabric. Sudden sliding or spinning of the truck tires can tear the fabric. A smooth continuous rolling movement is advised. Under no conditions should an operator attempt to turn the steering wheel while the equipment is stopped as this will tear the fabric.

A motor grader will be needed to spread the gravel evenly across the fabric. The moldboard on the grader should be tilted forward to give a dragging action. The grader operator should *not* try to spread the gravel in thin lifts (less than 2 ½ inches). Trying to blade a thin lift will cause the gravel to lock together and will drag the gravel across the fabric. This will result in tearing of the fabric. The end result should be a four inch thickness of gravel across the fabric. Avoid turning the front wheels of the grader while it is not moving, as this too will tear the fabric.

In the event of having to place fabric and gravel in boggy or extremely wet and soft locations the following techniques are recommended.

- Roll the fabric across the problem area, starting about 30 feet from the soft area.

- End dump trucks can be used to place the gravel if the trucks back dump the gravel, keeping at least 4 inches of gravel between the tires and the fabric.
- The end dump trucks should dump the gravel in a pile on one end of the fabric. A small dozer or front end loader can then push the gravel out ahead of the machine as long as four inches of gravel is between the tracks or tires of the equipment and the fabric.
- **Don't** use a motor grader to spread the initial layer of gravel. The front wheels of the grader are about ten feet in front of the blade and will be on the bare fabric. This will cause the fabric to be pushed down into the mud, making large ruts.

### Summary

- Shape the roadway and establish a crown.
- Roll the fabric across the problem area. Weight the ends, sides, and folds as necessary.
- Spread the gravel in the appropriate manner and in the direction of the laps.
- In soft conditions, keep four inches of gravel between the machinery and the fabric.
- If grading is required at a later date, care should be taken not to cut too deeply on a pass. Instead, cut only about one inch at a pass.

# Chapter 4

## Equipment Operation

### 4.1

#### Walk-Around Check

#### Pre-Start Procedures

1. Grease the machine according to the Operator's Manual. As you grease the machine, check for loose, worn, or broken parts; hydraulic system leaks; worn hoses; and leaks under the machine.
2. Check engine oil level.
3. Check coolant level in the radiator.
4. Check belts for adjustment and wear.
5. Check hydraulic oil level if equipped with hydraulic controls.
6. Check power steering reservoir.
7. Check air cleaner and connections and dump the dust cup if the machine has one.
8. Check fuel level and drain water from the fuel tank.
9. Check transmission oil level on power shift transmissions.
10. Lubricate the blade circle with graphite, diesel fuel or a mixture of diesel fuel and motor oil, according to Operator's Manual recommendations.
11. Check tires and wheels.
12. Check starting motor oil level if your machine has one.
13. After starting, check gauges, clutch free play, steering, lights and controls. Other checks indicated in the Operator's Manual may be necessary on certain types of machines, but these points cover the general checks.
14. Drain the condensate from the air tanks.

#### Starting Procedures

1. Make sure the parking brake is set and place the transmission in neutral.
2. For machines equipped with electric starting, open the throttle 1/4 and use the starter.
3. Always depress the clutch to lighten the load on the starter.
4. Never operate the starter continuously for more than 30 seconds. Then wait 2 minutes before using the starter again.
5. After the motor starts, check all gauges to see if they are operating. After 3 or 4 minutes of idling, set a fast idle to complete the warm-up.
6. Work the controls to make sure they operate and to warm up the hydraulic oil.

### General Shut-Down Procedures and End-trip Checks

1. Always cool out the engine for 3 to 5 minutes before shutting down.
2. Before leaving the cab lower all hydraulic equipment to the ground and set the parking brake.
3. Make a walk-around check including:
  - Loose, worn or broken parts,
  - Hydraulic system hose and connection leaks, and
  - Any oil, grease, coolant or fuel leaks.
4. After shutting down, check fuel, oil, coolant levels and blade wear; needed items can be brought out in the morning. If your blades are cupped in the middle and are not wearing straight, chances are you are not operating properly. See Chapter 1.1-1.3 “Drainage and Crowning” of a gravel road to find out how to correct this problem.
5. Clean accumulations of dirt or mix that might hinder the proper functioning of any sliding surface, pivot point or lubrication fitting. Hardened mix can be removed by pouring diesel fuel on the build-up area and allowing the mix to soften.
6. Always park the machine as near to level as possible.

## 4.2

### Moldboards

Moldboards are identified as the business end of motorgraders. A grader is useless without one, and not fully effective or efficient if the one it has is incorrectly adjusted, worn out, or improperly used.

### Settings

The ways that moldboards are set or adjusted determine their ability to cut, shape, move, smooth, and mix gravel road materials.

### Angle

The moldboard's angle is its position, in degrees, relative to a line perpendicular to the roadway centerline. It's not as complicated as that sounds. With the moldboard at a right angle to the road's centerline, it's considered to be angled 0 degrees, no angle. Moving one end of the moldboard forward 20 degrees produces a 20-degree angle; moving it forward 45 degrees produces a 45-degree angle; and so on. The closer the moldboard gets to parallel with the centerline, the greater becomes the angle. The greater the angle, the faster the gravel will come off the back end of the moldboard. Lesser angles keep the gravel in front of the moldboard longer, thus mixing it more.

Now, to keep things straight, the ends of the moldboard usually are not referred to as front, back, lead, or trailing, or even left and right. Instead, the terms used are toe and heel, just as in referring to feet. And it's just that easy to know which

is which. The leading end of the moldboard is always the toe, and the trailing end is the heel. Either end can be the toe, and either end can be the heel, depending on their relative positions (Problems Associated With Gravel Roads 5-28.)

### Pitch

Moldboards can be pitched, tilted, forward, or back, according to what the operator wants to accomplish with the cutting edge. On most motorgraders, pitch is controlled hydraulically. A full forward pitch causes the cutting edge to drag the gravel surface. A full backward pitch causes the cutting edge to cut into the surface. Pitch the moldboard gradually back from full forward and it will provide increasingly less dragging and more cutting action. Push it forward from the full back setting and it will provide increasingly less cutting and more dragging action.

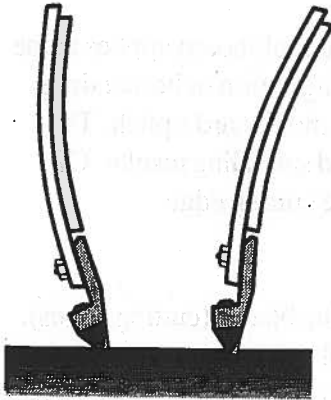

Figure 4.1-Blade Pitch

The cutting pitch of moldboards puts the beveled point of the cutting edge in position to slice into the surface, much like a chisel, with the bevel flat against the bottom of the surface material being removed. This produces the best cutting action with the least effort, and it keeps the bevel point from wearing down prematurely. Too much forward pitch makes the edge try to dive deeper. Too little forward pitch makes the edge climb back out.

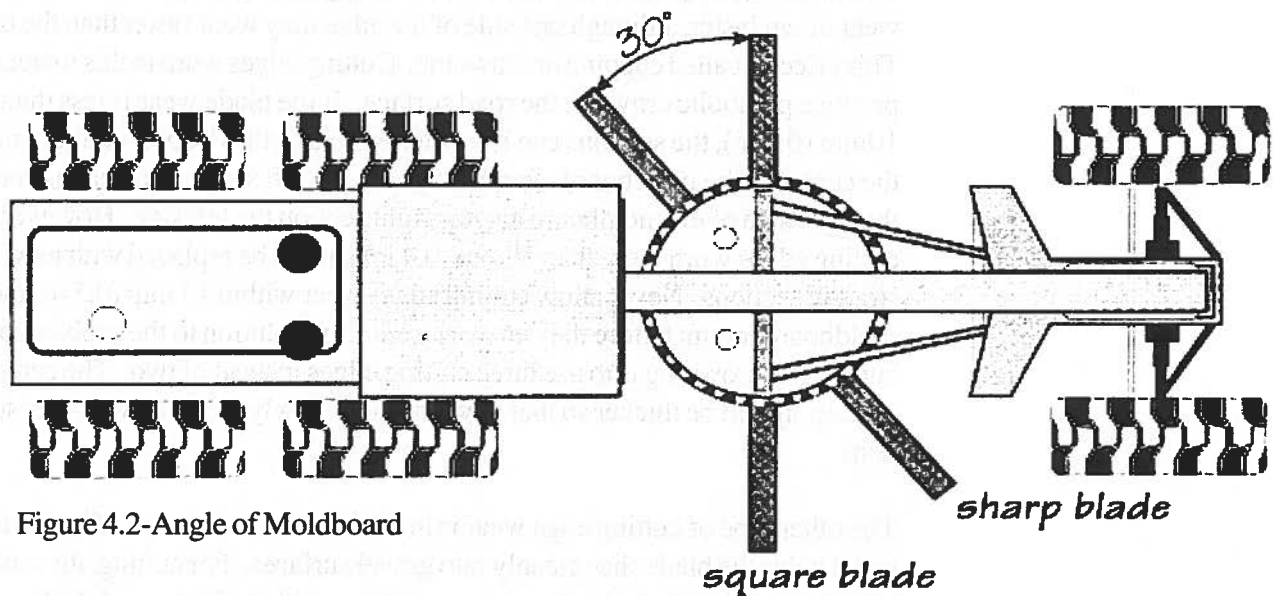

Figure 4.2-Angle of Moldboard

For smoothing or scraping with sharp, new cutting edges, the moldboard is pitched forward so that it drags across the surface. In this position, removing surface material depends on putting enough force on the cutting edge to scrape off the high points. The grader's down pressure plus its forward motion provide the necessary force.

Between the cutting and smoothing pitches there are a number of different moldboard positions. The right pitch for mixing depends on the grader's speed.

Generally, the correct mixing pitch is slightly back of vertical, but variations are needed to accommodate different materials and get the best mixing action. Besides moldboard pitch, mixing is affected by the moldboard's angle and the grader's speed.

### **Pressure**

The operator controls the downward pressure that the moldboard applies to the road surface. Increased pressure means deeper cutting action or harder dragging/smoothing/compacting action, depending on the moldboard's pitch. The pressure is also varied to produce different mixing and spreading results. Of course, greater pressure also means more wear on the cutting edge.

### **Blade Wear**

Most of the wear on moldboards is concentrated on the blades (cutting edges). Because of the abrasive nature of gravel road materials and the long hours of heavy work that graders put in, new blades can wear down quickly. Improper grader operation will accelerate this wear. Blades wear down mainly in two ways.

The first way is a pattern in which the blade edges in the middle of the moldboard wear down faster, although one side of the edge may wear faster than the other. This effect is called cupping or crowning. Cutting edges worn in this manner may produce parabolic crown in the road surface. If the blade wear is less than 10mm (0.4 in), the sections can be switched so that the deepest ends are now in the center of the moldboard. In other words, the left section can be moved to the right side of the moldboard and the right section the left side. However, cutting edges worn more than 10mm (0.4 in) should be replaced with new, straight sections. Never allow cutting edges wear within 13 mm (0.5) of the moldboard mount before they are replaced. One solution to the problem of cupping or crowning is to use three cutting edges instead of two. The center section should be thicker so that it wears more slowly than the two outer sections.

The other type of cutting edge wear is in the bevel of the blades. The 60 degree bevel helps the blade slice cleanly into gravel surfaces. For cutting, the moldboard should be pitched to the proper position, with the bottom of the bevel riding parallel to the road surface. A moldboard not properly pitched for cutting exposes the tip of the beveled edge to direct abrasion, dulling it and wearing it down very quickly. Bevels wear down differently depending on the grader operation, smoothing and spreading versus cutting.

### **Scarifying Blades**

The cutting edges or blades discussed so far are the conventional smooth, even-edged replaceable sections. In recent years, scarifying-blade systems have been developed as an alternative to the conventional moldboard cutting edges. Rather than smooth, even-edged blades, these systems use teeth-like bits to cut into the



surface and to process and spread the surface materials. The bits are either fixed or rotating, depending on the specific system. In winter they are used effectively to break up hard-packed snow and ice. They also show great potential for outperforming conventional blades in penetrating, screening, and smoothing gravel roads.

The bits of these scarifying-blade systems are easily replaced and are made of carbide steel for greater resistance to abrasion and, therefore, longer wear. Either through different bit widths or variable bit spacings these systems are able to leave the fines with the gravel instead of separating them. Some local agencies are able to use less-expensive pit-run material in place of more costly processed aggregate because the bits screen out the oversize rock and waste it on the shoulder. In effect, these systems provide an on-board processing capability.

Scarifying blades perform better where there is embedded shelf rock because they avoid snagging, especially the rotating bits. Even when there is damage to one or more bits, they are far easier and cheaper to replace than is an entire cutting edge. Because of their penetrating action, scarifying blades also can remove large embedded rocks from the surface, a task that smooth-edged cutting blades cannot do. Of course, where the surface has a good crust and only minor smoothing of the surface is called for, scarifying blades are undesirable because they will disturb the existing crust.

### **Wear Points**

The condition of the grader cutting edge affects how fast and well a road can be smoothed or reshaped. A lot of power is needed to cut washboard ridges and blend materials. Using a worn out cutting edge reduces the working speed of the grader by about half. Check the condition of your grader cutting edge each time you start to blade to see if it needs replacing.

You can tell if you are blading properly by looking at the used bit pile in your yard. The used bits should be straight. If they are badly cupped, chances are the county roads have parabolic crowns and poor drainage. Parabolic crowning is caused by not achieving a straight cross slope from the centerline to shoulder, and may develop during blading with bits that are worn or cupped in the middle.

The easy way to ensure even wear on the bit is to maintain a straight cross slope from centerline to shoulder, with equal force all the way across the moldboard. The hard way is to blade one mile on the right half of the roadway, and the next mile on the left side of the roadway so that the wear on the bit will be even.

You can cause excessive wear on the bits by blading dry roads. In order to determine if there is enough moisture in the road, take a handful of the material in front of the blade and make a fist. If it crumbles, it is too dry. If it stays together in a ball, it is just right.

### 4.3

#### Safety

Prevention of accidents involving powered equipment is completely dependent on the person operating the equipment. No power-driven equipment, regardless of the type or the purpose for which it is used, can be safer than the operator. The manufacturer can incorporate features to make the operator's job safer, and controls to make it easier, however:

**AVOIDING SITUATIONS THAT MAY PRODUCE ACCIDENTS IS SOLELY UP TO THE PERSON AT THE CONTROLS, THROUGH FORETHOUGHT, JUDGEMENT AND SKILL.**

A careful operator is the greatest safety device there is. Stop accidents before they stop you.

Most graders have been designed to incorporate every safety device possible. Even with all these safety features, however, there are still dangers. The operator must be extremely careful in the operation of a big machine like this. In order to help prevent accidents the following safety rules should be observed at all times.

1. Become well acquainted with the piece of equipment, the Operator's Manual, and Maintenance Manual. Know where all controls are located and what they operate.
2. All power equipment should be operated only by those who are responsible and delegated to do so.
3. In areas of possible danger, obey the decals located on the grader.
4. For safe operation observe proper maintenance and repair of all pivot points, hydraulic cylinders, hoses, snap rings and main attaching bolts, and inspect prior to each day's operation.
5. Keep the operator's platform free of debris.
6. Be sure no one is under or around the machine before starting.
7. Always face the machine when mounting and dismounting the grader.
8. Never jump from any machine.
9. Always maintain a firm grip on the hand holds while entering or leaving the machine, and until you are in the seat or your feet are on the ground.
10. Clean your shoes of slippery materials to prevent slipping on steps, or off the pedals.
11. Keep windshield, windows, and mirrors clean at all times.
12. Pull the keys before servicing or repairing grader.
13. Check all controls to be sure they are operating correctly before putting the machine to work.
14. Do not leave the machine unattended with the engine running.
15. When shutting down, always cool engine 3 to 5 minutes. Lower all hydraulic equipment to the ground and set parking brake before leaving the cab.
16. Never coast the machine with transmission in neutral or with clutch disengaged. Maintain a ground speed consistent with conditions.

17. Avoid operation too close to banks or overhangs.
18. Be sure to shut the engine off when refueling, and do not smoke.
19. When you must work with hydraulic equipment raised, be sure to block it securely with blocks that will not crush.
20. Never operate the machine in a closed shed or garage: establish good ventilation and open the doors.
21. Do not oil, grease or adjust the machine when the engine is running, unless the operator manual specifies how to perform that operation.
22. Drive at speeds slow enough to insure safety and complete control, especially over rough terrain.
23. Increase the power gradually when pulling a heavy load or when driving out of a ditch or excavation.
24. Reduce speed when making a turn or applying brakes.
25. Keep brakes in proper adjustment. If you can't stop the machine, don't start it.
26. Never make repairs or tighten hydraulic hoses or fittings when the system is under pressure, when the engine is running, or when cylinders are under a load.
27. Be careful removing the radiator pressure cap when the radiator is hot.
28. Be very careful when using cold weather starting fluid. Wait at least ten minutes before using starting fluid if you have attempted to start the engine with a manifold heater. Crank the engine 5 to 10 seconds before attempting to use a manifold heater if you have used starting fluid first.
29. Always disconnect the battery ground strap before making adjustments on the engine or electrical equipment and before welding on any part of the unit. This will prevent dangerous sparks which create a fire hazard and may cause harm or damage. Disconnecting the battery also prevents accidental operation of the starter, or battery explosion.
30. Never permit persons other than the operator to ride on the grader.
31. Sound the horn before moving the grader.
32. Always look behind the grader before backing up.
33. Always be sure of water, gas, sewage, electrical and telephone line locations before you start any cut operations.
34. Always check overhead clearance, especially when transporting the unit. (Know your maximum height before transporting.)
35. When deadheading the grader, always have the blade toed to the off traffic side, and carried high.
36. To prevent highway accidents, use workzone traffic control signs. Turn on yellow flashing cab lights whenever working on road surfaces. Display the "Slow Moving Vehicle" emblem.
37. Practice good housekeeping and clean out the cab at the end of each day.
38. It is the responsibility of the operator to make an inspection of the grader each shift. The use of defective or unsafe equipment is forbidden.
39. Look for leaks and check fluid levels.
40. Use safety equipment provided with the machine for your protection.

*\* Use common sense and good judgement. \**



# Chapter 5

## Maintenance of Unpaved Roads-Near Wetlands

*Added from NACE  
Drainage & Stormwater  
Management Action  
Guide*

### 5.1

#### Introduction

Maintaining unpaved roads that run along streams, lakes and wetlands require careful operation because unnatural sediment loads can negatively impact these aquatic resources.

Erosion from exposed or disturbed soils can reach 151 tons per acre per year. During a road construction project in Virginia, about half of the 151 tons stayed in the drainage and 76 tons were transported from the watershed. This is about 10 times that normally expected from cultivated land, 200 times that from grassland, and 2,000 times that from forest land. Erosion from disturbed soils can be catastrophic for the watersheds. During a four year project in Virginia, erosion occurred equalling 40 years of soil cultivation, 800 years under grass, and 8,000 years under forest (*NACE Action Guide III-8 Soil Erosion and Water Pollution Prevention, Chapter 2*).

The Montana Department of Environmental Quality at the Environmental Protection Agency's direction, has listed (303d list) over 1300 miles of streams in Montana with full or partial impairments, due in part to road construction and/or road maintenance activities.

#### What is a Wetland?

Despite the difficulty defining wetlands, they generally have one or more of the following characteristics:

- water on or near the surface, all or part of the year;
- distinctive poorly drained soils that develop certain physical characteristics due to the presence of water (referred to as hydric soils); and
- vegetation composed of species referred to as hydrophytes adapted to life in wet soils.

#### Why Are Wetlands Important?

Wetlands serve highly important ecological, economic, recreation, and aesthetic functions. In Montana, wetlands mitigate flood impacts, enhance water quality, improve biological productivity, increase recharge of ground water, and provide direct human benefits. These benefits are described below.

#### Flood Impact Mitigation

Wetlands reduce the volume and physical energy of water by providing the following measures.

**Flood Peak Reduction.** Wetlands store large volumes of water during snowmelt and heavy rains, reducing storm peak runoffs and slowly releasing runoff over a longer time period. Drainage of wetlands and conversion to other land uses removes this “sponge” effect, causing rapid runoff in a short period which can intensify flooding and may result in stream channel instability.

**Shoreline Stabilization.** Wetland vegetation acts as a buffer which absorbs and distributes flood waters, slows water currents and dissipates wave energy, thereby lessening the potential for shoreline and floodplain erosion. The root systems of wetland vegetation bind the floodplain and shoreline soil to further resist erosive forces.

### **Water Quality Enhancement**

Wetlands enhance the physical and chemical condition of water by providing pollution control and nutrient removal and transformation.

**Pollution control.** Wetlands provide retention for sediments and toxic substances. Suspended solids and chemical contaminants such as pesticides, petroleum and oils and heavy metals may be retained and deposited in wetland. Deposition of sediments can ultimately lead to removal of toxins from the environment through burial or assimilation into vegetation. Microorganisms can further break down the pollutants into stable harmless components.

**Nutrient Removal and Transformation.** Wetlands act as natural water purification mechanisms. They remove silt and filter out and absorb nutrients such as nitrogen, phosphorus and potassium through oxidation, reduction, assimilation or other biochemical processes. In some parts of the nation, wetlands are sometimes used in wastewater treatment.

### **Biological Productivity**

Wetlands are the most biologically productive ecosystems on earth; they provide habitat that supports a diverse array of wetlands-dependent species.

**Freshwater Fish.** Nearly all freshwater fish require shallow water provided by wetlands at some stage of their lives for spawning, shelter from extreme environmental conditions, and feeding. Many wetlands, where connected with deepwater habitats, provide ideal fish brooding and rearing habitat.

**Habitat for Threatened and Endangered Species.** Almost 35 percent of all rare, threatened and endangered animal species in the U.S. are either located in wetland areas or are dependent on them, although wetlands constitute only about 5 percent of the U.S. land mass. Protecting habitat for these species helps the recovery process for those who are endangered and helps ensure that additional species do not become endangered. Care and consideration around streams or wetlands where endangered species exist should be of top priority.

Rare Plant Habitat. Both of Montana’s federally listed threatened and endangered plant species occur in wetlands.

Nutrient Cycling. Wetlands enhance the decomposition of organic matter, incorporating nutrients back into the food chain.

**National Goal of No Net Loss of Wetlands**

Wetlands are now recognized as valuable resources that support wildlife, purify polluted waters, help contain the destructive power of floods and storms, provide diverse recreational activities, and increase property values. President Carter in 1977 signed Executive Order (EO) 11990 which applies to federal agencies such as the Bureau of Land Management, Forest Service, and Bureau of Reclamation. EO 11990 specifies that lands meeting the definition of a wetland under the Clean Water Act and other federal and state laws are subject to all applicable federal, state, and local regulations. This means that when federal lands are proposed for lease, easement, right-of-way, or disposal to non-federal parties, special protective requirements for wetlands must be made part of the package. In addition Presidents Bush and Clinton have endorsed a federal policy goal of preserving the remaining wetlands with “No Net Loss.”

A National wetland goal evolved during meetings of the National Wetlands Policy Forum. The Forum is a group representing all major interests in wetlands policy, including government, agriculture, industry, and environmental advocates. In November 1988, after examining the wetland issue for a year, the forum published its final report. It recommended that:

....the nation establish a national wetlands protection policy to achieve no overall net loss of the nation’s remaining wetland base, as defined by acreage and function, and to restore and create wetlands where feasible the quality and quantity of the nation’s wetlands resource base.

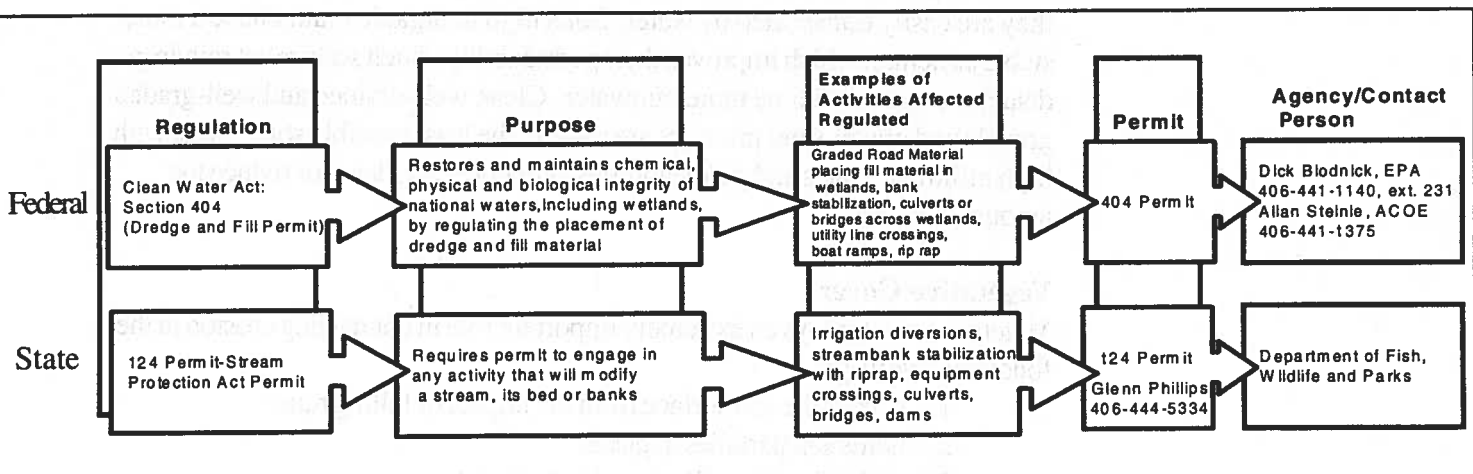

Figure 5.1- Regulations Flow Chart

### **Regulations Governing Wetlands**

**Federal Government.** Wetlands are considered waters of the U.S. and as such are regulated under the Clean Water Act by the Army Corps of Engineers (ACOE). All activities of fill and dredge are regulated by the federal government.

**State Government.** Activities that modify the bed of a stream or bank are governed by the state of Montana. Government agencies working in these areas are required to obtain a 124 permit. Private citizens are required to obtain the state 310 permit administered by local Conservation Districts.

## **5.2**

### **Factors Influencing Erosion**

The inherent erosion potential of any area is determined by four principal factors, the characteristics of soil, the vegetative cover, the topography, and the climate. Although each of these factors is discussed separately herein, they are interrelated in determining erosion potential.

#### **Soil Characteristics**

Soil characteristics which influence erosion by rainfall and runoff are those properties that affect the infiltration capacity of a soil as well as those which affect the resistance of the soil to detachment and of being carried away by falling or flowing water. The following four factors are important in determining soil erodibility.

1. Soil Texture (particle size and graduation)
2. Percentage of organic content
3. Soil Structure
4. Soil Permeability

Soils containing high percentages of fine sands and silt are normally the most erodible. As the clay and organic matter content of these soils increases, the erodibility decreases. Clays act as a binder to soil particles, thus reducing erodibility. However, while clays have a tendency to resist erosion, once eroded they are easily transported by water. Soils high in organic matter have a more stable structure, which improves their permeability. Such soils resist raindrop detachment and infiltrate more rainwater. Clear, well-drained and well-graded gravels and gravel-sand mixtures are usually the least erodible soils. Soils with high infiltration rates and permeabilities either prevent, delay or reduce the amount of runoff.

#### **Vegetative Cover**

Vegetative cover plays an extremely important role in controlling erosion in the following five ways:

1. shields the soil surface from the impact of falling rain;
2. holds soil particles in place;
3. maintains the soil's capacity to absorb water;
4. slows the velocity of runoff; and
5. removes subsurface water between rainfalls through the process of evapotranspiration.



By limiting and staging the removal of existing vegetation, and by decreasing the area and duration of exposure, soil erosion and sedimentation can be significantly reduced. Special consideration should be given to the maintenance of existing vegetative cover on areas of high erosion potential such as erodible soils, steep slopes, drainageways, and the banks of streams.

### **Topography**

The size, shape and slope characteristics of a watershed influence the amount and rate of runoff. As both slope length and gradient increase, the rate of runoff increases and the potential for erosion is magnified. Slope orientation can also be a factor in determining erosion potential. For example, a slope that faces south and contains arid soils may have such poor growing conditions that vegetative cover will be difficult to reestablish.

### **Climate**

The frequency, intensity, and duration of rainfall are fundamental factors in determining the amounts of runoff produced in a given area. As both the volume and velocity of runoff increase, the capacity of runoff to detach and transport soil particles also increases. Where storms are frequent, intense, or of long duration; erosion risks are high.

When precipitation falls as snow, no erosion will take place. In the spring, however, the melting snow adds to the runoff and erosion hazards are high. Erosion can also be increased because the ground is still partially frozen, and thus its absorptive capacity is reduced.

## **5.3**

### **Sedimentation**

Excessive quantities of sediment cause costly damage to water resources and to private and public lands. Sediment fills drainage channels, especially along highways and railroads, and plugs culverts and storm drainage systems thus necessitating frequent and costly maintenance.

In any given reach, a stream constantly adjusts itself. It is balancing the amount of water and gradient of the channel, and the amount and size of sediment. Any disturbance, either natural or human-caused, will alter this balance. The addition of excessive quantities of sediment is especially disruptive to a stream channel because excessive sediment can cause the elevation of the streambed to rise. This rise causes the water to migrate into one of its stream banks, which causes further bank erosion. The erosion results in more sedimentation, which can result in additional channel bed elevation rise resulting in further erosive cycles in the system.

Our activities such as modifying streams, diverting or adding water, building in floodplains, or removing vegetation can limit a stream's ability to maintain a

balance. An unbalanced stream is an unhealthy stream. Fine-grained sediments, such as clays, silts and fine sands, when in excess concentration in an aquatic environment can drastically reduce both the kinds and the amounts of organisms present. Sediments alter the existing aquatic environment by screening out sunlight and by changing the rate and the amount of heat radiation. Particles of silt settling on stream and lake bottoms form a blanket which creates a hostile environment for the organisms living there including fish and literally smothers many of them and their eggs.

Coarser-grained materials can also blanket bottom areas and suppress aquatic life found on and in these areas. Where currents are sufficiently strong to move the bedload, the abrasive action of these materials in motion accelerates channel scour.

#### **Avoid disrupting vegetation on road shoulders near lakes, streams and wetlands.**

As previously noted, ground cover is the most important factor in terms of preventing erosion. Any existing vegetation which can be saved will help prevent erosion. Trees and other vegetation protect the soil as well as beautifying the site after construction. Obviously, once plant growth is established on road shoulders, it should be disturbed only when absolutely necessary.

#### **Minimize road maintenance 100 feet before and after live stream crossings (fords) to reduce sedimentation.**

In some cases, road stabilization and compaction may also be used. On some low volume roads in Montana economies dictate that a bridge or culvert would not be feasible. Water may only be present several months during the year at which time water may be swift enough to remove small culverts. In such locations vehicles are required to cross a live stream. On such roads maintenance should be minimized to reduce added sedimentation.

#### **Avoid grading excess material off road shoulders whenever possible.**

Shoulders are the most important roadway area from the standpoint of erosion to the roadbed. Shoulder erosion quickly exposes road core material and exposes the roadbed. This erosion weakens the shoulder and pavement surface and presents a hazard to vehicles that must leave the surfaced area.

Establishing and maintaining adequate turf on roadway shoulders is often a difficult task. Some reasons contributing to this are:

- poor growing media – road core material slightly below the surface;
- heavy flows of water from the surfaced area;
- concentrations of salt and sand;
- plowed wet snow that results in ice sheets and smothering;
- rapid and extreme changes in temperature as a result of being near the surfaced areas; and
- high variable winds resulting from passing vehicles, especially trucks.

Shoulders and shoulder slopes are the most likely areas of the roadside to become weed infested. An eroded condition greatly increases the possibility of weed infestation.

Fill-slope surfaces protect, and are part of the road core. They are often subject to gravitational erosion, slides, slips, sloughs, and slumps. Gravitational erosion (slip) on a roadway slope is a result of a slip plane created between the subsoil and topsoil. This may be avoided by the use of deep-rooted plants, such as alfalfa. In addition, the fill surface can be scarified prior to topsoil placement.

#### **5.4 Types of Erosion**

The four types of erosion are; raindrop splash, sheet erosion, rilling, and gullying.

##### **Raindrop Splash**

The erosion process is initiated with the raindrop splash. The raindrop impacts the soil with tremendous energy causing the soil particles to be dislodged or detached. Raindrops typically fall with velocities in the 6 to 9 meters/second (20 to 30 feet/second) range. The energy imposed on the ground surface can cause soil particles to be splashed more than 0.6 meters (2 feet) vertically and 1.5 meters (5 feet) laterally.

In addition to the erosion, the impact of the rainfall on bare soil can change the structure of the soil. The impact destroys the open structure of the soil and increases the compaction. Fine particles and organic matter are separated from heavier soil particles reducing the infiltration capacity of the soil and increasing the runoff potential. The resulting compacted soil structure also inhibits plant establishment.

The role of rainfall splash in the erosion process cannot be over emphasized. This is the first step in the erosion process and should be minimized through erosion control techniques. The method used to prevent erosion from raindrop splash is stabilization. This includes establishment of temporary and permanent vegetation, mulching, and the use of erosion control matting and blankets.

##### **Sheet Erosion**

Sheet erosion is the removal of soil from sloping land in thin layers or sheets. Sheet erosion is the transporting mechanism of soil loosened by the raindrop splash. The potential for sheet erosion is a function of soil type, and depth and velocity of flow on the slope. In erodible materials, the potential increases with the length and steepness of slope as well as the contributing drainage area.

Sheet erosion is a primary concern in highway construction due to the presence of cuts and fills. The same stabilization methods used for the rainfall splash should be applied to prevent sheet erosion. In addition, it can be minimized by

diverting as much flow as possible away from the exposed slope. Any structural practice that will reduce the amount of runoff contributing to the exposed area will reduce the sheet erosion.

### **Rill Erosion**

Rill erosion is the erosion which develops as the shallow surface flow begins to concentrate in the low spots of the irregular conformation of the surface. As the flow changes from the shallow sheet flow to deeper flow in these low areas, the velocity and turbulence of flow increases. The energy of this concentrated flow is able to both detach and transport soil materials. This action begins to cut tiny channels of its own. Rills are small but well-defined channels which are at most only a few inches deep.

### **Gully Erosion**

Gully erosion occurs as the flow in rills comes together in larger and larger channels. The major difference between this and rill erosion is a matter of size. Gullies are too large to be repaired with conventional tillage equipment and usually require heavy equipment and special techniques for stabilization. Channel erosion occurs as the volume and velocity of flow causes movement of the streambed and bank materials.

## **5.5**

### **Stabilization**

The key to successful erosion and sediment control is the prevention of erosion. In highway construction and maintenance, this is best achieved through effective stabilization of the slopes and waterways. By initially preventing erosion from occurring, the overall net loss of sediment from the site is minimized. Stabilization is achieved with temporary and permanent turf establishment, mulching, erosion control mats and blankets. It is much more effective to prevent erosion from occurring than to try to filter or trap sediment with other measures. Controls based on the principles of filtering and trapping have limited efficiencies and are used as backup measures. Vegetation is the best and most permanent method of erosion control.

### **Gravel Filter Berms - Construct gravel filter berms on road shoulders closest to lakes, streams or wetlands.**

Gravel filter berms can be an effective means of controlling erosion and sediment caused on road shoulders by raindrop splash and sheet erosion. Construction of a gravel filter berm is accomplished by grading a berm onto the toe of the shoulder. Gravels must be sufficiently coarse to allow water to seep through the berm without dislodging the gravel. Care should be exercised to make sure that the berm does not have the unintended effect of channeling water flow and causing even greater flows and resulting erosion.

**Design Criteria**

- Berm material shall be  $\frac{1}{4}$  to 3 inches in size, washed, well-graded gravel or crushed rock with less than 5 percent fines.
- Spacing of berms:  
Every 300 feet on slopes less than 5 percent  
Every 200 feet on slopes between 5 to 10 percent  
Every 100 feet on slopes more than 10 percent
- Berm dimension:  
1 foot high with 3:1 side slopes

**Maintenance**

- Regular inspection is required; sediment shall be removed and filter material replaced as needed.

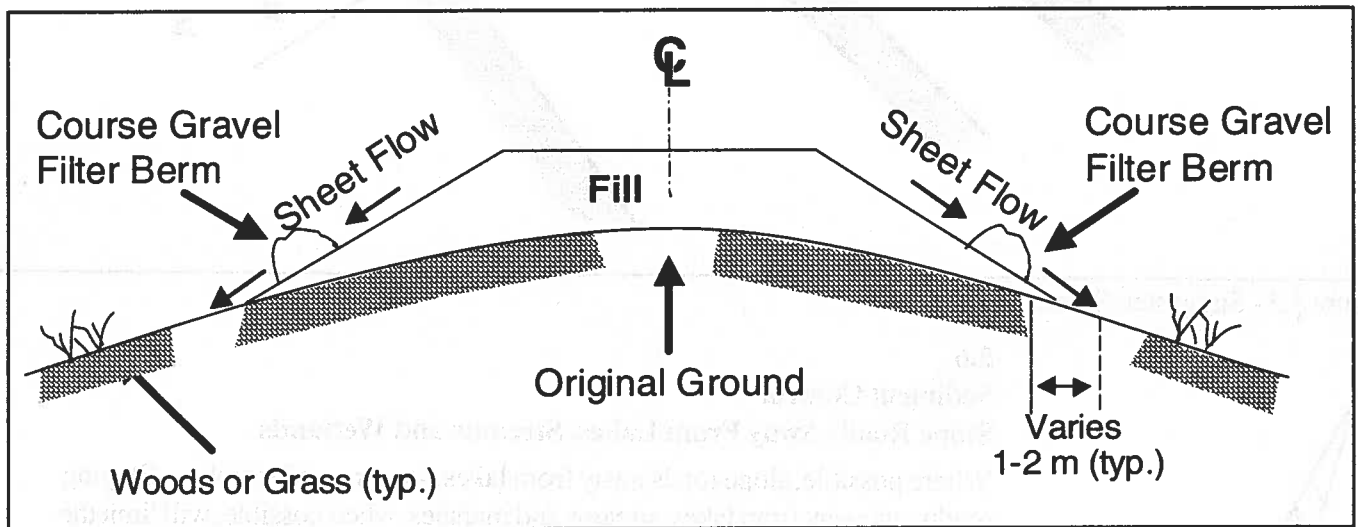

Figure 5.2 - Placement of Gravel Filter Berms

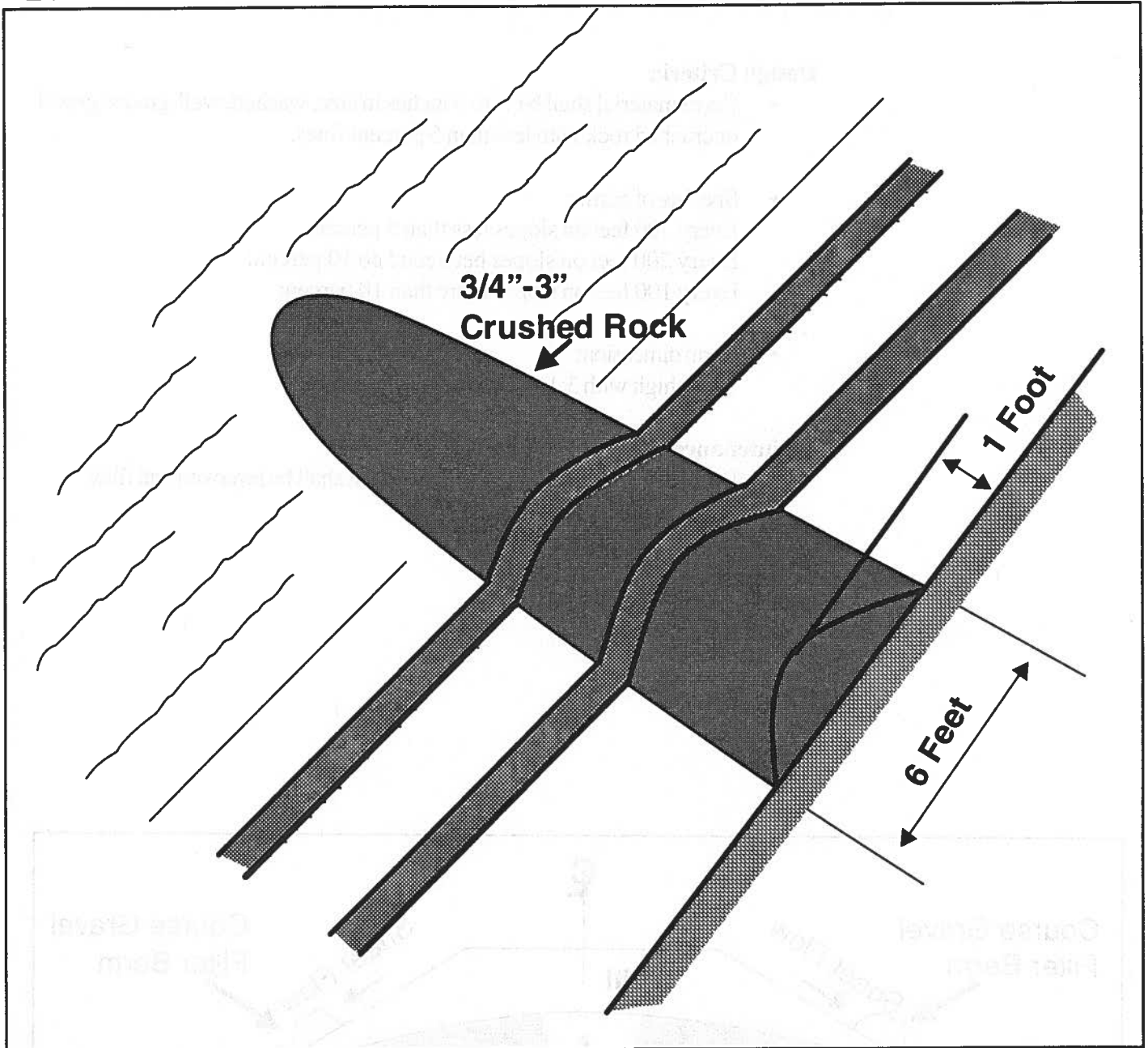

Figure 5.3 - Suggested Size of Berms

**5.6  
Sediment Control  
Slope Roads Away From Lakes, Streams and Wetlands**

Where possible, slope roads away from lakes, streams and marshes. Sloping roadways away from lakes, streams and marshes, when possible, will limit the flow of sediment into these waters. It may become necessary to haul away excess material from the inside shoulder (see portion of Figure 5.4).

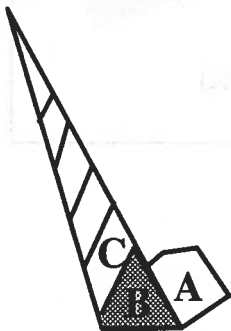

Figure 5.4-Cleaning  
Ditches Beneath a Cut

Avoid undercutting established slopes when removing material. When excess material is removed, care should be taken not to remove material shown in a portion of Figure 5.4. For soil to regain its material angle of repose a great deal of material shown in a portion of Figure 5.4 would then fall in to the cut ditch and on the roadway.

### Silt Fences and Straw Bales

Use silt fences or straw bales to contain concentrated runoff. Silt fences and straw bales can be used to control small water flows which are generally referred to as sheet erosion and rill erosion. Those terms are defined as follows.

#### Silt Fence

A silt fence is a temporary barrier used to filter sediment from sheet flow. This barrier can also cause water to pond behind the fence thereby promoting deposition of the sediment. The fence is constructed with a synthetic filter fabric mounted on posts and embedded in the ground. This is the most common type of control used to remove sediment before the runoff leaves the site.

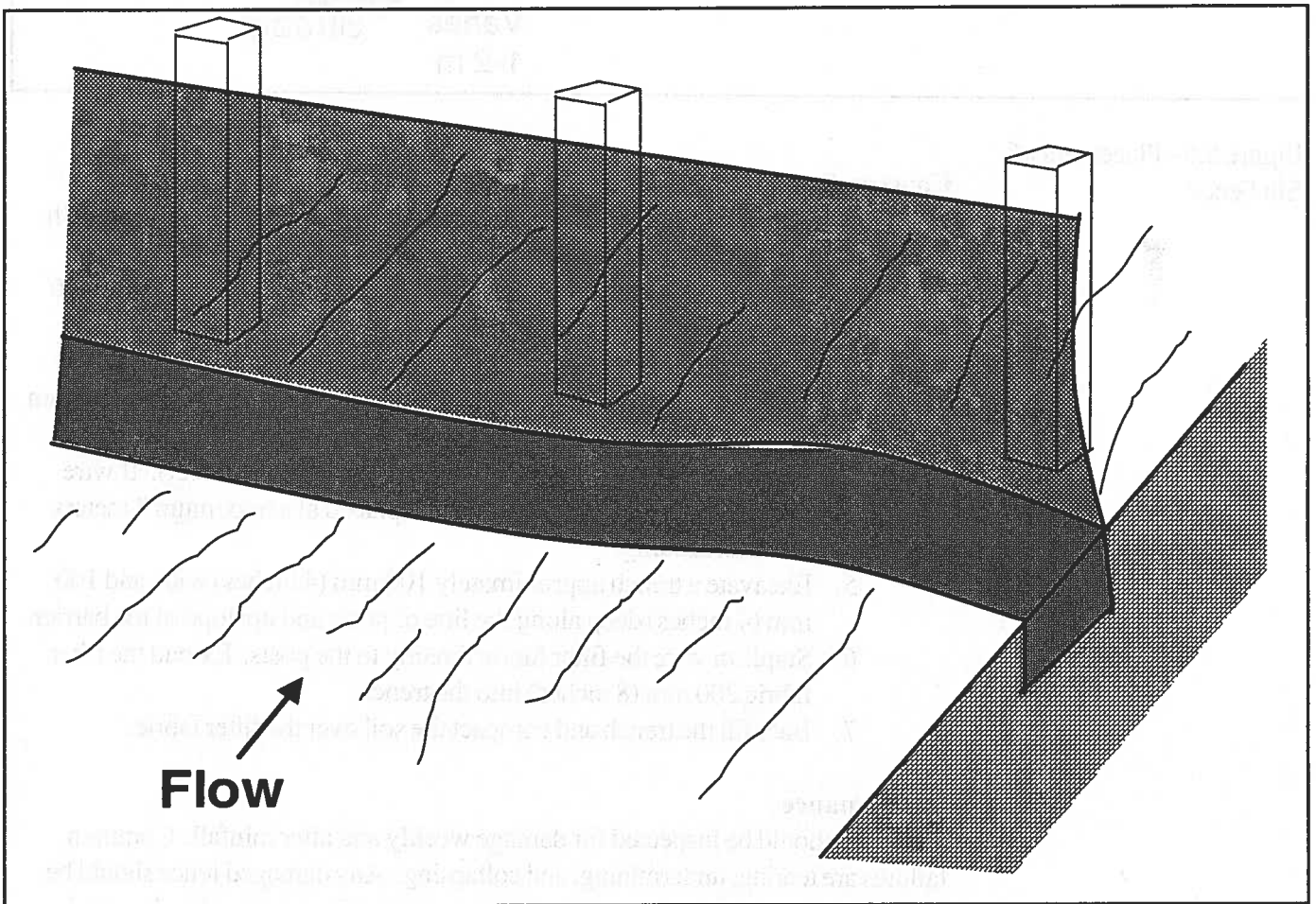

Figure 5.5 - Use of Silt Fences

Silt fence is commonly placed at the toe of fills and along the edge of waterways to trap sediment before it enters the waterway. Silt fence is not intended for use in ditches and swales where flows are concentrated. It may be used in minor ditches and swales.



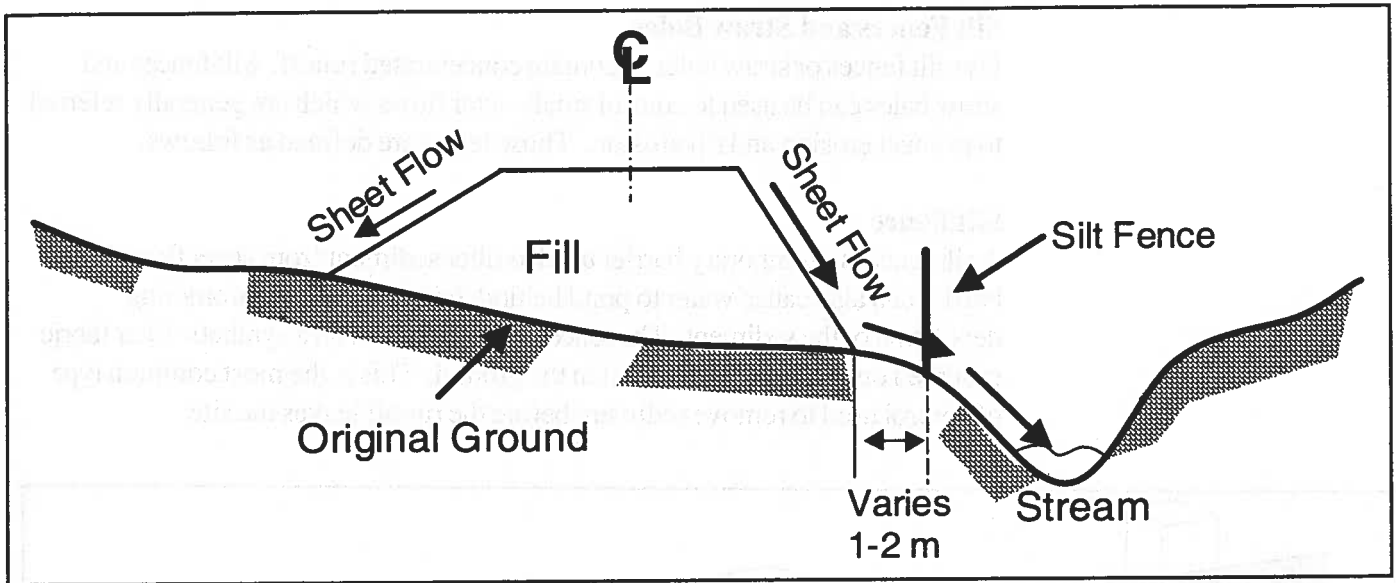

Figure 5.6 - Placement of Silt Fence

#### Construction

1. Construct the silt fence barrier of standard strength or extra strength synthetic filter fabrics.
2. Ensure that the height of the silt fence does not exceed 900 mm (36 inches) above the ground surface.
3. Construct the filter fabric from a continuous roll cut to the length of the barrier to avoid joints. When joints are necessary, securely fasten the filter cloth only at a support post with overlap to the next post.
4. Place posts at a spacing not to exceed 1.8 meters (6 feet). If wire mesh backing is used, posts may be placed at a maximum 3 meters (10 feet) spacing.
5. Excavate a trench approximately 100 mm (4 inches) wide and 100 mm (4 inches) deep along the line of posts and upslope of the barrier.
6. Staple or wire the filter fabric directly to the posts. Extend the filter fabric 200 mm (8 inches) into the trench.
7. Backfill the trench and compact the soil over the filter fabric.

#### Maintenance

Silt fence should be inspected for damage weekly and after rainfall. Common failures are tearing, undermining, and collapsing. Any damaged fence should be repaired immediately. Accumulated sediment should be removed and properly disposed of before the next rainfall. When the disturbed areas have been properly stabilized, the fence may be removed and any remaining areas stabilized.

#### Straw Bales

Straw bales are temporary measures used to filter sediment from runoff in sheet flow applications. Straw bales are recommended only for applications of short duration, usually less than 3 months, due to the tendency to degrade quickly and to fill up with sediment causing water to flow around bales.



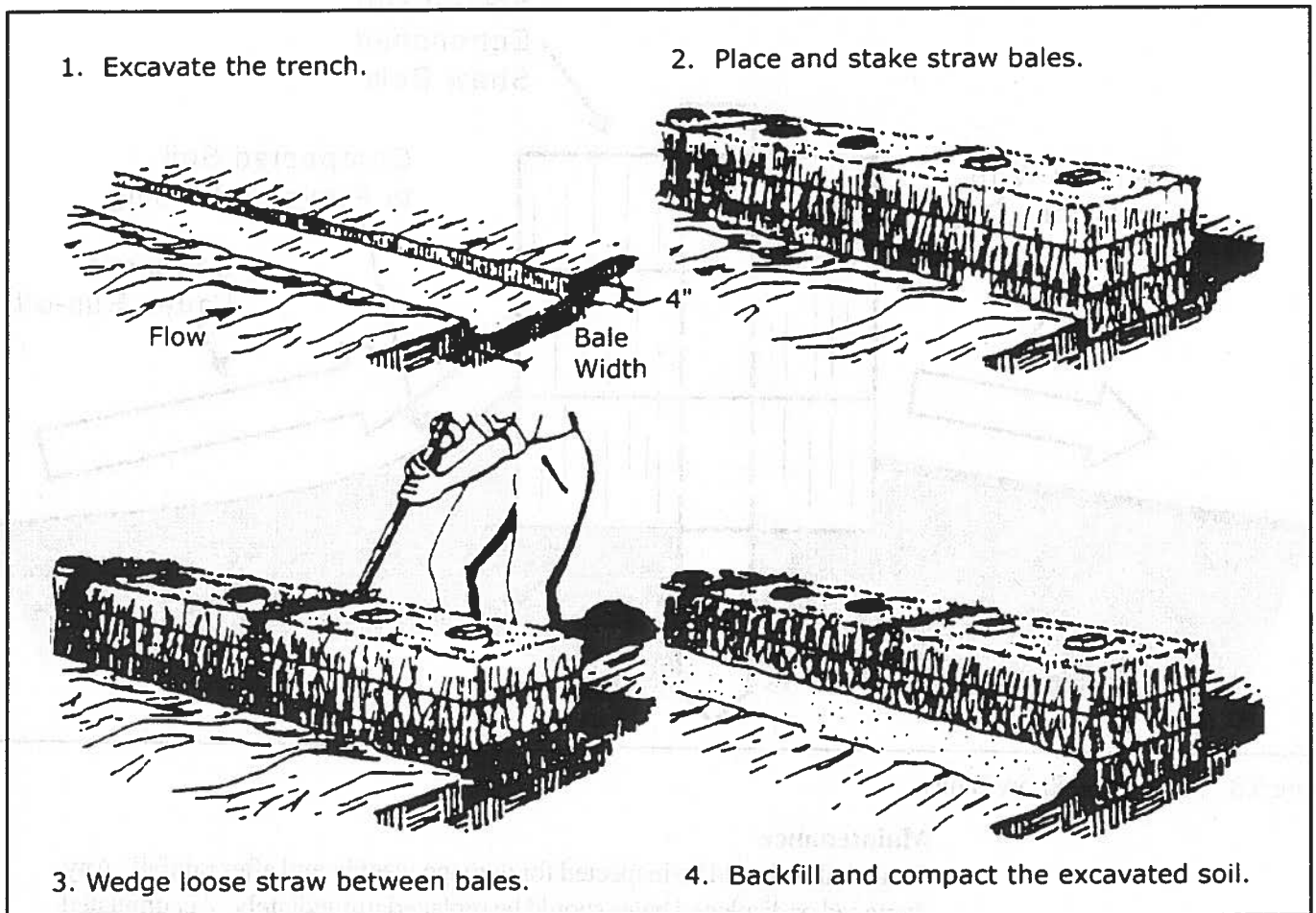

Figure 5.7- Placement of Straw Bales

### Construction

1. Place bales in a single row, lengthwise on the contour with ends of adjacent bales tightly abutting one another.
2. Use bales that are either wire-bound or string-tied. Install straw bales so that bindings are oriented around the sides rather than along the tops and bottoms of the bales (in order to prevent deterioration of the bindings).
3. Entrench and backfill the barrier. Excavate a trench the width of the bale and the length of the proposed barrier to a minimum 100 mm (4 inch) depth. After the bales are staked and gaps between the bales have been chinked with straw, backfill the excavated soil against the barrier.
4. Securely anchor each bale with at least two stakes or rebars driven through the bale. Drive the first stake in each bale toward the previously laid bale to force the bales together. Drive the stakes or rebars a minimum 300 mm (12 inches) into the ground.

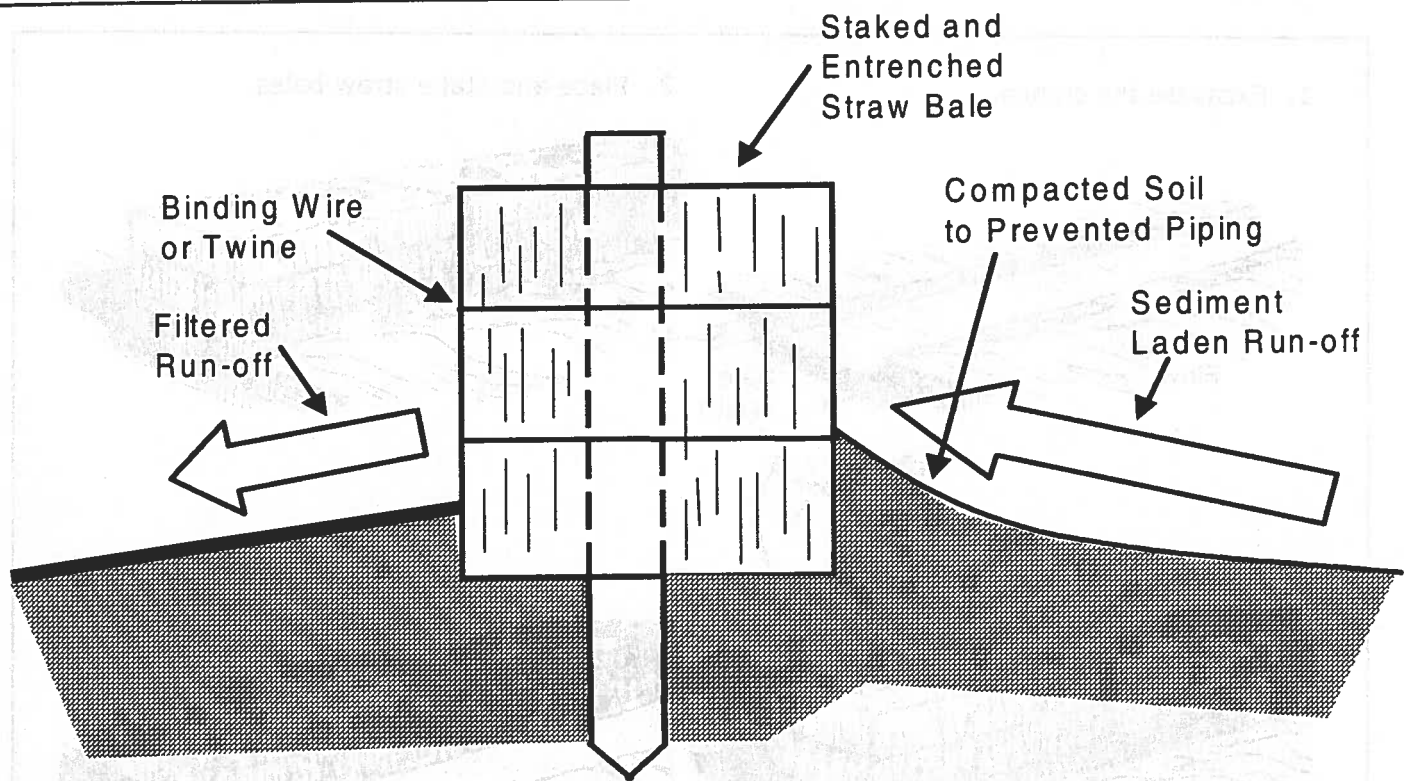

Figure 5.8 - Function of Straw Bales

#### Maintenance

Straw bales should be inspected for damage weekly and after rainfall. Any damaged or displaced bales should be replaced immediately. Accumulated sediment should be removed and properly disposed of before the next rainfall. When the disturbed areas have been properly stabilized, the bales may be removed and any remaining areas stabilized.

#### Riprap

Riprap can cause permanent changes to natural flow. For this reason riprap should be used on outfalls from drainage ways only, not in live streams. Use riprap, water steps and check dams to avoid excess erosion in drainage outfalls. Riprap and water steps are used to control relatively large flows in drainage ways. When stabilizing stream banks, vegetation stabilization and root wads are preferable to riprap.

Riprap consists of sorted field stone. It may be placed by hand randomly or grouted. Riprap is effective for erosion control in culvert scour holes, and in the lining of channels. The rock should be of sufficient size and weight for the amount and velocity of water encountered. Riprap helps control erosion by slowing the velocity of water and holding down the soil.

In a channel lined riprap, the entire length of the gully should be shaped so that water stays on the riprap and does not form a new channel.

**Water Steps and Check Dams – These measures should be used only where large storms cause excessive damage to otherwise dry drainage outfalls.**

Water steps and check dams are small, temporary obstructions in a ditch or drainage outfall used to prevent erosion by reducing the velocity flow. Water steps and check dams placed in the ditch or drainage outfall causes water to pond behind the structure thereby reducing the velocity and force acting on the soil or lining. Although some bed material may be deposited behind the structure, water steps and check dams do not function as sediment trapping devices, and should not be used as such. If bed elevation of the ditch or drainage outfall rises too much because of sediment filling in behind the water step or check dam, there can be lateral movement causing additional bank erosion.

Water steps and check dams are most commonly constructed of loose rock riprap and sometimes logs or compacted earth. Silt fence or straw bales should not be used as substitutes for water steps and check dams due to stability problems, however, these materials may be used in swales with very low flows to filter runoff. Care should be taken to clean these facilities so that silt does not fill in, causing water to flow around them.

### **Design**

A standard check dam is 0.6 meters (2.0 feet) high with a 1.2 meter (4.0 feet) base (Figure 5.9). These dimensions may be modified based on the individual needs and for larger flows.

The spacing between structures is dependent on the height of the check dam, the grade of the waterway and the desired length of the backwater effect. In order to protect the ditch or drainage outfall between the water steps or check dams, the devices should be spaced such that the elevation of the toe of the up gradient water step or check dam is equal to the elevation of the crest of the water step or check dam down gradient.

On steeper slopes, the ponding of the water will not extend as far up gradient as on flatter slopes. For this reason, water steps or check dams are not as effective on steep slopes.

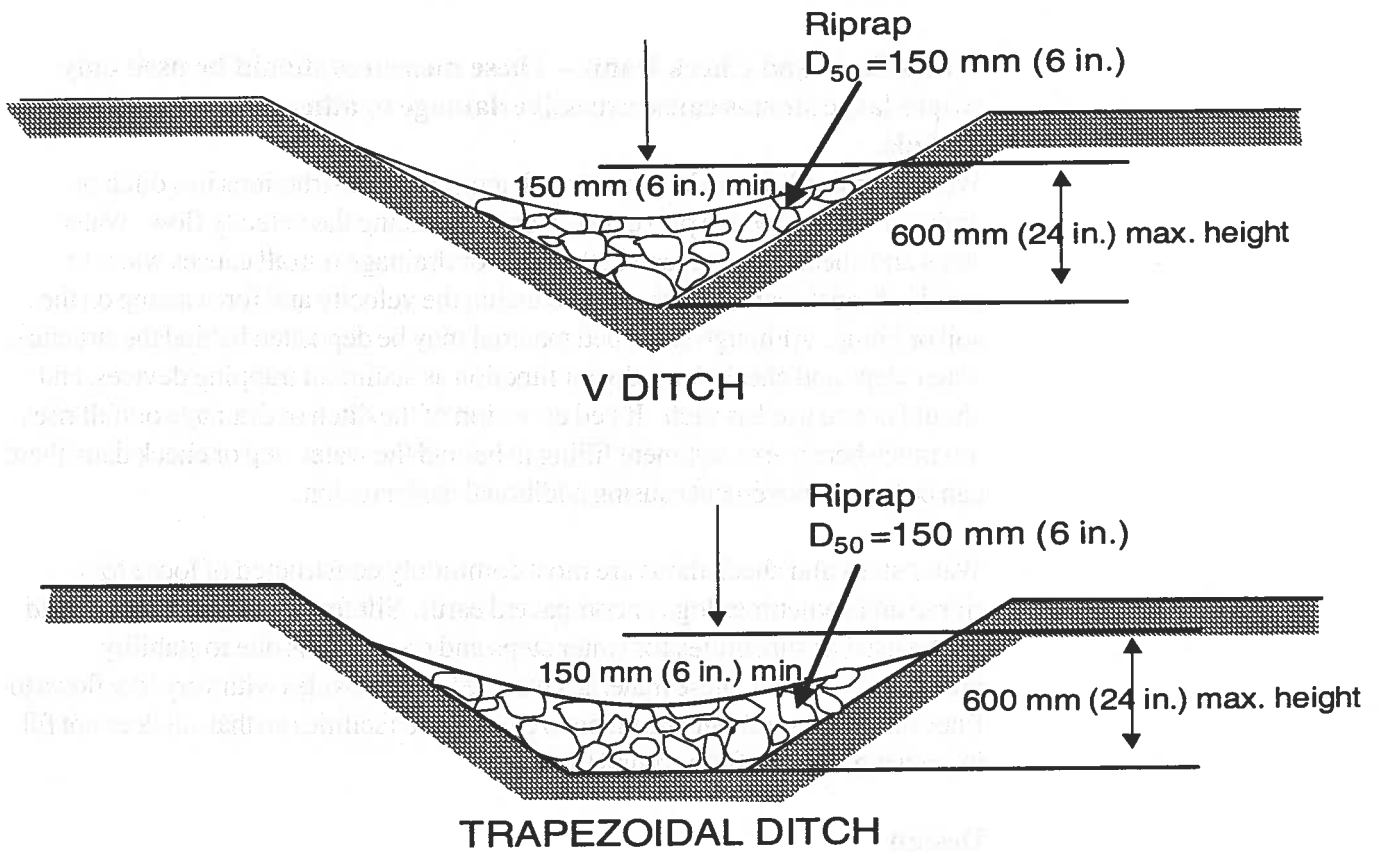

Figure 5.9-Cross Section of Water Steps

$L$  = The distance such that points A and B are of equal elevation

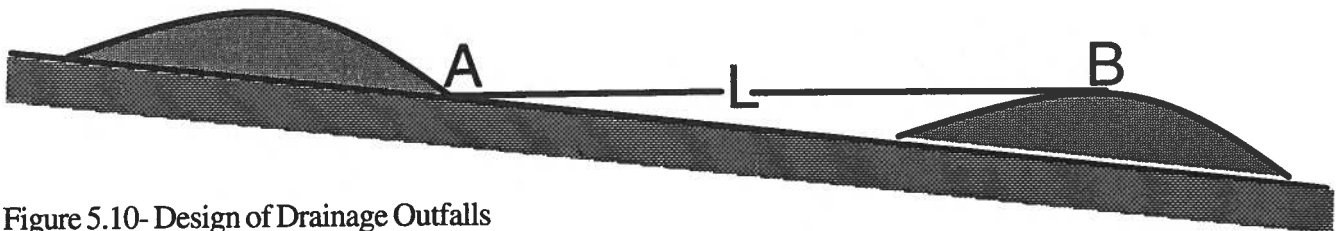

Figure 5.10- Design of Drainage Outfalls

### **Construction**

1. Place stone in locations as shown in the plan on a filter fabric foundation.
2. Unless different dimensions are specified, the base of the check dam should be 1.2 meters (4 feet) wide with 2 horizontal to 1 vertical side slopes. The maximum height of the check dam should be 0.6 meters (2 feet) with the center 150 mm (6 inches) below the sides of the dam.
3. The spacing of the check dams should be specified in the plan or such that the elevation of the toe of the up gradient check dam is equal to the elevation of the crest of the down gradient check dam.

### **Maintenance**

Check dams should be inspected after rainfall to ensure proper functioning. Large flows can cause sediment accumulation, wash-outs, or damage to filter material. The overflow areas and toe of the check dam are especially susceptible to erosion. These areas should be stabilized immediately if any damage has occurred. Also, any displaced stones should be replaced. Remove and properly dispose of sediment when it has accumulated half way up the dam height or it interferes with the performance of the structure.

### **Channel Water To Prevent Erosion**

Channel water to areas where erosion can be prevented and settling can occur. One of the fundamental rules of controlling erosion and sedimentation is to retain the sediment on the site. We discussed earlier how by using controls such as silt fence and straw bales, sediment can be filtered from runoff before it leaves the site. These devices should be used only for sheet flow or low concentration of flow. Where flow occurs in greater quantities, runoff can be detained in settling structures until the particles settle out. These temporary devices are called sediment traps, or for larger areas, sediment basins. Settling structures are suitable where disturbed areas of sufficient size drain to one location. The structure's size is based on the contributing drainage area.

### **Temporary Sediment Traps**

A sediment trap is a temporary structure that is used to detain runoff from small drainage areas so that sediment can settle out. These devices are constructed by excavation and construction of an embankment that will provide a determined storage volume. The flow from the structure, or release, is controlled by a rock spillway or pipe outlet. Sediment traps are generally limited to a contributing drainage area of two hectares (five acres).

When properly designed, located, and constructed, sediment traps can perform at efficiencies of up to 80%. They are excellent perimeter controls, provided that runoff from disturbed areas drains to one location, and sufficient right-of-way and storage volume are available.

Traps should only be used to intercept runoff from disturbed areas. It is inefficient to route clean runoff through a sediment trap.

### **Location**

The location of sediment traps is critical in their design and should be determined based on the existing and proposed topography of the site. As a perimeter control, locate the trap where one to two disturbed hectares (two to five acres) drain to one location. Try to choose a location where maximum storage can be obtained from the natural topography. This will minimize the required excavation. This location should be at a site that will minimize interference with construction activities and will allow the trap to remain in service until the site is stabilized. The site must be accessible for future clean-out of the sediment trap. Also, evaluate the risk of failure of the structure and the consequences of failure.

### **Storage Volume**

In order for the sediment trap to function properly, it is important that the required storage volume be provided. An engineer should be consulted for this important design calculation.

### **Construction**

1. The area under the embankment should be cleared, grubbed, and stripped of all vegetation and root mat. The pool area should be cleared to reduce debris buildup and facilitate cleanout.
2. Excavate as required in the plan to obtain the necessary storage volume.
3. Use fill material for the embankment that is free of roots and other woody vegetation, organic material, large stones, and other objectionable material. Compact the embankment in 200 mm (8 inch) layers by traversing with construction equipment.
4. Construct the riprap spillway to the dimensions shown on the plan. Place filter fabric beneath all riprap.
5. Provide temporary or permanent stabilization of the embankment immediately after construction.

### **Maintenance**

Sediment shall be removed and the trap restored to its original dimensions when the sediment has accumulated to one-half of the wet storage volume. Removed sediment shall be deposited in a suitable area and in such a manner that it will not erode. The structure shall be inspected after each rain and repairs made as needed.

## 5.7

### Dust Control Practices

Dust can affect water quality of early lakes and streams. Much of the material can end up in live streams and lakes. It is believed that by stabilizing the surface material, water quality will be greatly enhanced by reducing sedimentation.

### Magnesium Chloride

One of the best methods of stabilizing road and eliminating road dust is the use of Magnesium Chloride. Magnesium Chloride is a natural salt substance that is pumped from ground-water ponds near the Great Salt Lake. It is mixed with anti-corrosive agents and sprayed on roads as a dust suppressant and prior to storms to prevent ice from forming and bonding to the road surface.

Magnesium chloride is used as an alternative to sanding and can reduce dust and sediment from migrating into streams and reduce amounts of sand placed on roadways during winter use.

A recent two-year \$190,000, study performed by the Colorado Department of Transportation concluded that magnesium chloride caused “no impact on aquatic life.” However, there haven’t been any studies on the long-term environmental impacts or impacts to humans.

### Regraveling costs versus road surface treatments.

Chapter 6 presents a study performed by Colorado State University used four test sections to compare dust reduction on gravel roads due to applications of lignosulfonate, calcium chloride, and magnesium chloride. The charts (Table 6.5) show that regraveling a road costs nearly double what it costs to retain material on roadway using treatment. There would also be a significant reduction in the migration of sediment to streams and lakes. The study also shows at what traffic volume it is economical to use dust suppressants.

### Salt and the Environment

In this age of environmental concern, salting of roads and streets has developed as one governmental function where control and good judgement can minimize damage to roadside vegetation and local water supplies. The environment has been buffered against salt for millions of years. To an extent, salt is even essential for plant and animal growth. But excessive amounts of sodium and chloride ions may have deleterious effects on water, soil and vegetation.

Runoff from highway deicing operations can effect roadside wells, small ponds and other water supplies near the roadway. Avoid use of salt (including blocks) near lakes, streams and marshes. Large bodies of water are seldom affected by deicing salt runoff. In a study of sodium and chloride content of Maine rivers, Hutchinson found levels ranging from 6 to 18 parts per million (ppm). He reported: “It can be concluded...that sodium and chloride ion concentration in

rivers of Maine are not being seriously affected by salt materials applied to highways for purposes of deicing.”(NACE Action Guide Drainage & Storm Water).

Road salting is one of the many factors contributing to a hostile roadside environment for vegetation and water quality. Compacted soil, injuries due to construction, roots that are covered or exposed due to earth movement or paving and auto exhaust emissions also contribute to vegetation decline along roadsides. Relative high concentrations of sodium and chloride ions in soils may adversely affect plant growth. Large quantities of salt can affect trees by interfering with the mechanism that lets plants absorb moisture from the soil. Most salt-caused damage occurs to vegetation within 30 feet of the roadside. Symptoms of salt damage are more severe on vegetation that is close to or below the elevation of the road. Most turf grasses are salt-tolerant. For example, alkali grass resembles Kentucky bluegrass and is so tough it thrives on highway shoulders that receive high quantities of deicing salt. Kentucky 31 fescue demonstrates the highest salt resistance among grasses tested. Treating the roadside soil with gypsum appears to be a successful method of satisfactorily amending the soil to correct conditions brought on by years of salting and resulting sodium buildup.

### **Minimize Application Rates**

The following are some of the ways in which maintenance crews can hold down the application rates of salt.

- Calibrating spreaders and keeping them properly calibrated through the winter season.
- Spreading salt as soon as enough snow has fallen to hold the salt on the pavement. This prevents ice buildup and avoids the need for repeated salt applications.
- Giving salt previously applied sufficient time to go into solution before plowing it to the sides of the road.
- Spreading salt in the right place on the road surface – for example, on the high side of elevated curves so the salt brine runs down and across the pavement.
- Controlling the spinner speed so salt stays on the pavement instead of falling into gutters or onto shoulders.

Spreader calibration is perhaps the most important factor in controlling the amount of salt that is applied.



# Chapter 6

## Dust Control

### 6.1

#### Road Dust Suppressants

##### The Problem

Dust is more than just a nuisance on unpaved roads, it is the cause of many problems.

- By obscuring the vision of drivers, dust clouds are a traffic hazard.
- Dust can carry several hundred feet, penetrating nearby homes and covering crops. Crop growth is stunted due to the shading effect and clogged plant pores.
- In human health, dust is a common cause of allergies and hay fever and may be a conveyor of diseases.
- Fine abrasive particles greatly increase wear on moving parts of a vehicle.
- The loss of a road binder, in the form of dust, represents a significant material and economic loss.

The severity of a dust problem is determined primarily by the speed and amount of traffic on the unpaved road. The condition is aggravated by long dry spells, softer road aggregates that abrade under traffic to produce more dust, and initially excessive soil binder in the surface mix. Without binder material and adequate moisture, the coarser material will be thrown or washed away from the road surface. The road begins to ravel, rut, and washboard; deterioration accelerates until costly repairs are needed.

##### The Solution

Dust control using chemical or mechanical suppressants can be justified when:

- paving is not feasible for lack of funds or limited use of the road,
- the cost of materials and application is low, and
- stage construction of the road is planned.

The problem of dust from unpaved roads is a worldwide problem. Methods of treatment in the United States range from spraying roads with chemicals, chiefly chloride compounds and resinous adhesives, to utilizing geotextiles in road reconstruction.

When chemicals are applied to the road surface to control dust, the surface should first be crowned and shaped to final grade, to assure good drainage. For

all but resinous adhesives, the road must be pre-wetted with water (if natural moisture is lacking) to assist chemicals in penetrating the surface.

### **The Choices**

A number of organic and inorganic chemical mixes are available for use as dust palliatives; synthetic fabrics are also available for physically containing the road materials. The selection of a particular dust suppressant will depend not only on its performance characteristics, but also on the type and volume of traffic, roadway condition, and product cost (material, freight, and application) to achieve the desired level of dust control. These criteria will vary significantly. Some successful cost-saving measures have been reported, for example, treating only a center strip of the roadway on less-traveled roads or spot-treating on a cost-share basis with roadside residents.

The adhesive and waterproofing characteristics of bituminous materials is well known, but cost is usually prohibitive unless the treatment precedes some type of asphalt paving. Lignin derivatives are natural cements that bind the dust particles, aided by associated sugars which act as hygroscopic agents; they are also excellent dispersing agents for clays, meaning reduced water penetration during wet periods. Various hybrid products are emerging (for example, a bitumen-lignin dust control agent), which pose opportunities for cooperative test projects.

## **6.2**

### **Relative Effectiveness of Road Dust Suppressants**

**“The Colorado Study”** A paper by T.G. Sanders, J.Q. Addo, A. Ariniello and W.F. Heiden, Colorado State University, 1994.

#### **Abstract**

The relative effectiveness of commercially available road dust suppressants in abating fugitive dust emission and loss of fines from unpaved road surfaces was assessed in a field based research project. The dust suppressants studied, lignin derivatives and chloride based compounds, were used on unpaved road test sections during the severe dusty months (late spring to fall) of 1993 and 1994 in Colorado.

To measure the relative effectiveness of the different dust suppressants, comparative fugitive dust emission studies were conducted on several unpaved road test sections using the Colorado State University Dustometer, a dust sampling device developed in this research. In addition, total aggregate loss from the surfaces of the test sections was measured. Based upon the prevailing costs, analyses were performed to determine the economics of using the different dust suppressants.

The research indicated that the use of the three dust suppressants studied reduced fugitive dust emission from the unpaved roadways by 50-70%. The total

aggregate losses from the treated test sections were 42-61% less than that of the untreated control test section. The cost savings of retaining aggregate on the treated test sections more than offset the costs of the dust suppressants, resulting in an estimated cost savings of 30-46% over the untreated control test section.

### **Introduction**

While unpaved roads carry a small portion of the nation's traffic, they provide a vital link in the nation's economy. Of the nearly 4 million miles (6.5 kilometers) of road network in the continental U.S., it is estimated that about 65% are unpaved. One major problem associated with unpaved roads is traffic generated fugitive dust. To residents living along unpaved roads, the airborne dust penetrates their homes causing nuisances and health problems such as hay fevers and allergies. The fine suspended dust particles contribute significantly to the particulate matter loading in the atmosphere. According to air pollution studies, nearly 34% of the particulate matter in the atmosphere originates from unpaved roads nation wide, making unpaved roads one of the major man-made sources of fugitive dust. In addition to environmental degradation, the generation of dust means loss of aggregate and subsequent road surface deterioration as the loss of road surface fines in the form of dust leads to the formation of ruts, potholes and corrugations. These conditions represent a significant material and economic loss.

The severity of the dust problem is determined primarily by the volume of traffic using an unpaved road as well as the speed, weight, number of wheels of each vehicle, the abrasive resistance of the road surface and the amount of fines in the initial road surface material mix. The climatic condition of the region is also an important factor affecting the generation of dust from unpaved roads. Long dry spells that often occur in semiarid and arid regions aggravate the road dustiness.

The high maintenance cost of unpaved roads in terms of aggregate replacement, the increased public awareness of pollution problems, and the high road user cost has led agencies responsible for the maintenance of roads to have a renewed interest in dust control measures. Frequently used dust control methods include reduction of vehicular speed, application of water, and use of dust suppressing chemicals. Although dust suppression has been in practice for decades, quantitative studies on the effectiveness of the different road dust suppressants and their environmental impact have been virtually nonexistent.

A study was conducted to evaluate, under field conditions, the relative effectiveness of some of the more commonly used road dust suppressants. Three commercially available dust suppressants were evaluated in the study: lignosulfonate (a by-product of the paper making industry), calcium chloride and magnesium chloride (both deliquescent and hygroscopic compounds). The road surface material used was crushed gravel mix from a local gravel pit.

### Experimental Design

The tests were performed on four unpaved road sections, each 1.25 miles long, in the Loveland area of Larimer County, Colorado. Three of the test sections were treated with the different dust suppressants, namely: lignosulfonate, calcium chloride ( $\text{CaCl}_2$ ) and magnesium chloride ( $\text{MgCl}_2$ ), while one of the sections was left untreated to serve as the control. All four test sections were part of the same stretch of an existing unpaved road.

Virgin crushed gravel material was used for the construction of the road surfaces. The gravel can be classified by the general name of scoria, according to the American Association of State Highway Officials Standard Specification. A

TEST	RESULTS
Atterburg Limits (ASTM No. D-423 & D-424)	Nonplastic and no cohesion
Los Angeles Abrasion Test (ASTM No. C-131)	30%
Soundness (ASTM No. C-88)	Not Determined
Specific Gravity (ASTM No. D-845)	2.60

Table 6.1-ASTM, Tests of

sieve analysis was performed on the aggregate mix according to ASTM Test No. C-136. The results of the analysis are represented in Figure 6.1. The quantity of the material passing the No. 40 (425 $\mu\text{m}$ ) standard sieve referred to as fine sand/silt is 9.6%. The fines fraction is noted to be directly related to the amount of dust emission from an unpaved road surface. Other tests to determine the engineering properties of the aggregate were also performed. They included: Atterburg limits to determine the plasticity of the road surface material; Los Angeles abrasion to determine the abrasive resistance of the aggregate mix and specific gravity. The tests and the results are listed in Table 6.1.

### Test Sections

The construction of the road test sections followed the procedures recommended in the highway engineering literature and that of the dust suppressants suppliers. Important application techniques for most dust suppressants include: road surface scarification, adequate grading and smoothing of the road surface, application of the dust suppressants in quantities sufficient for effective dust control, and a proper road finish procedure that includes the forming of the surface crown, optimum compaction of the road surface and proper drainage.

Approximately 4 inches (10.2 cm) of the virgin gravel material was laid on the existing roadway.

The primary equipment involved in the test section construction included:

- water trucks for adding water to the road surface material,
- motor graders for grading, mixing and shaping the roadway,
- a distributor truck with power spray bar for applying dust suppressant, and
- a vibratory steel drum compactor for compacting the road surface.

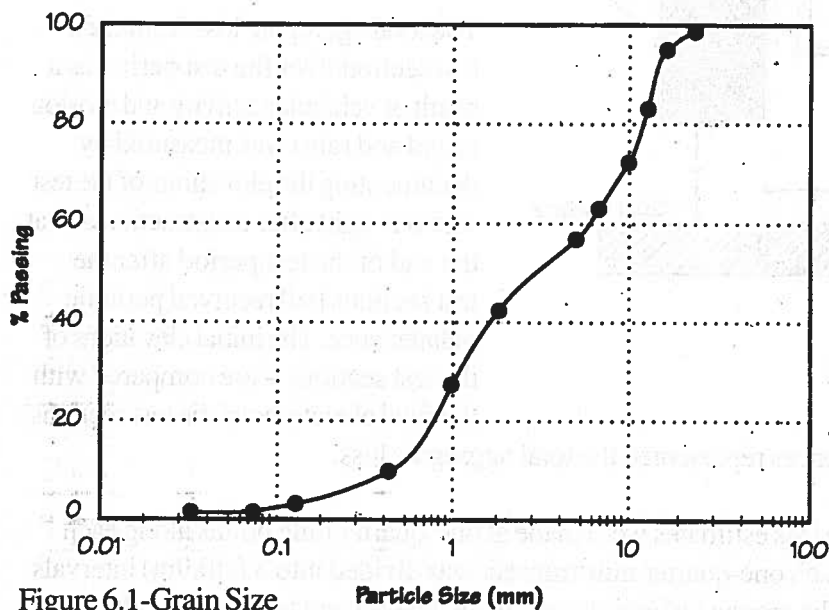

Figure 6.1-Grain Size Distribution

The application rate for the lignosulfonate as suggested by the supplier was  $\frac{1}{2}$  gal/yd<sup>2</sup> (2.3 lit/m<sup>2</sup>) of road surface and the method of application was mixed-in-place. The application rates for the CaCl<sub>2</sub> and MgCl<sub>2</sub> were the same at  $\frac{1}{2}$  gal/yd<sup>2</sup> (2.3 lit/m<sup>2</sup>) of road surface and the method of application was surface sprayed. The mixed-in-place application method involves the addition of the dust suppressant to the road surface material in-situ by mechanically mixing the suppressant with the road surface material. The surface sprayed application, on the other hand, involves the spraying of the dust suppressant under high pressure on the road surface after the road surface has been maintained (bladed, shaped and compacted).

### Measurements

Three fundamental field measurements were made. They were traffic counts, fugitive dust emissions, and total aggregate loss. The traffic survey of each test section was carried out by installing traffic counters at the beginning and end of each test section. The counters were left in place throughout the duration of the field measurements which started in late May and ended in early October 1994.

The dust emission from each test section was measured throughout the test period using the Colorado State University Dustometer. The Dustometer is simply a moving dust sampler developed, field tested, and used in this research. The device consists primarily of: 1) a fabricated metal box containing a 10 in. by 8 in. (25.4 by 20.3 cm) glass fiber filter paper, mounted to the bumper of a  $\frac{1}{4}$  ton pickup truck on the driver's side rear tire, 2) an electric generator and 3) a high volumetric suction pump. The fabricated filter box has a 12 in. by 12 in. (30.5 cm by 30.5 cm) opening that is covered with a 450 micron mesh sieve which faces

the tire. The micron screen prevents any non dust particles from being drawn onto the filter paper during dust measurement.

As the truck is driven at a constant speed of 45 mph (72.6 kph) a portion of the dust generated is collected on a pre-weighed filter paper in the filter box mounted on the bumper of the truck. At the end of a test run the filter paper is gently removed and stored. The filter box is refitted with a new pre-weighed filter paper and another test is run. The dust

laden filter papers are later weighed in the laboratory. Figure 6.2 shows a schematic diagram of the Colorado State University Dustometer setup.

Figure 6.2-Schematic Diagram of the Colorado State University Dustometer Setup

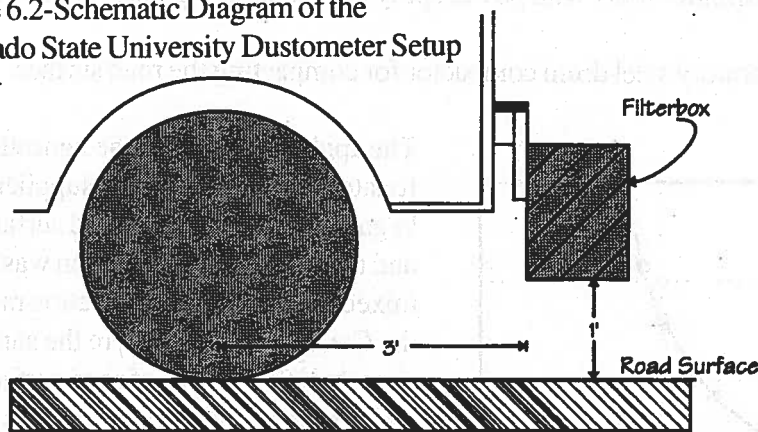

The total aggregate loss from each test section over the test period as a result of vehicular activity and erosion (wind and rain) was measured by documenting the elevations of the test sections right after construction and at the end of the test period after the test sections had received periodic maintenance. The initial elevations of the test sections were compared with the final elevations of the test sections

and the differences represented the total aggregate loss.

The aggregate loss estimates were made at one-quarter mile points along each test section. Each one-quarter mile transect was divided into 3 ft (0.9m) intervals starting from the crown. Using a dumpy level, levels were taken at the 3 ft intervals to document the initial elevations of the roadways immediately after construction. The test sections were then open to traffic for the duration of the test period after which they received period maintenance without additional aggregate or dust suppressants. Following the same procedure used in taking the initial elevations, the final elevations were taken and the difference between the two elevations was used to estimate the total aggregate loss.

## Research Results and Discussion

### Traffic Survey

The results of the traffic counts for each of the four test sections are presented in Table 6.2. There is a direct correlation between the number of vehicles using a roadway and the degradation of the roadway. The extensive traffic survey done was to measure as accurately as possible the number of vehicles using each test section so that aggregate loss could be expressed as per vehicle per mile.

Although all four test sections were part of the same stretch of unpaved county

road, it appears that the sections at the ends of the stretch, the lignosulfonate treated and the untreated test sections had higher traffic counts than the CaCl<sub>2</sub> and the MgCl<sub>2</sub> test sections located in the middle of the road. The lignosulfonate and the untreated test sections had Average Daily Traffic (ADT) of 515 and 538 respectively compared to 421 for the CaCl<sub>2</sub> and 448 for the MgCl<sub>2</sub> test sections.

**Dust Measurement**

The results of the fugitive dust measurements from each of the four test sections are shown in Figure 6.3. In all, 15 dust sampling measurements from each test section were made during the research period. Each data point in Figure 6.3 is an average of three measurements made by driving the Dustometer in the same

TEST SECTION	BEGINNING	END (# of Vehicles)	AVERAGE	ADT
Lignosulfonate	85,326	59,746	75,536	515
CaCl <sub>2</sub>	59,746	58,659	59,203	421
MgCl <sub>2</sub>	58,659	67,680	63,170	448
Untreated	67,680	83,895	75,788	538

Table 6.2-Average Daily Traffic Per Section

driving lane in the same direction. The length of each test section was one mile. The dust measurements were initiated 16 days after the completion of the test sections. During the test period the treated test sections did not receive any

periodic maintenance, while the untreated control test section received two periodic maintenances.

The average ambient temperature and relative humidity during the test period was approximately 88°F (31°C) and 34%, respectively. The amount of dust sampled from the lignosulfonate treated test section varied from a low of 0.05 gms when the treatment was new, to a high of nearly 0.6 gms measured towards the end of the test period. The CaCl<sub>2</sub> treated test section started with approximately

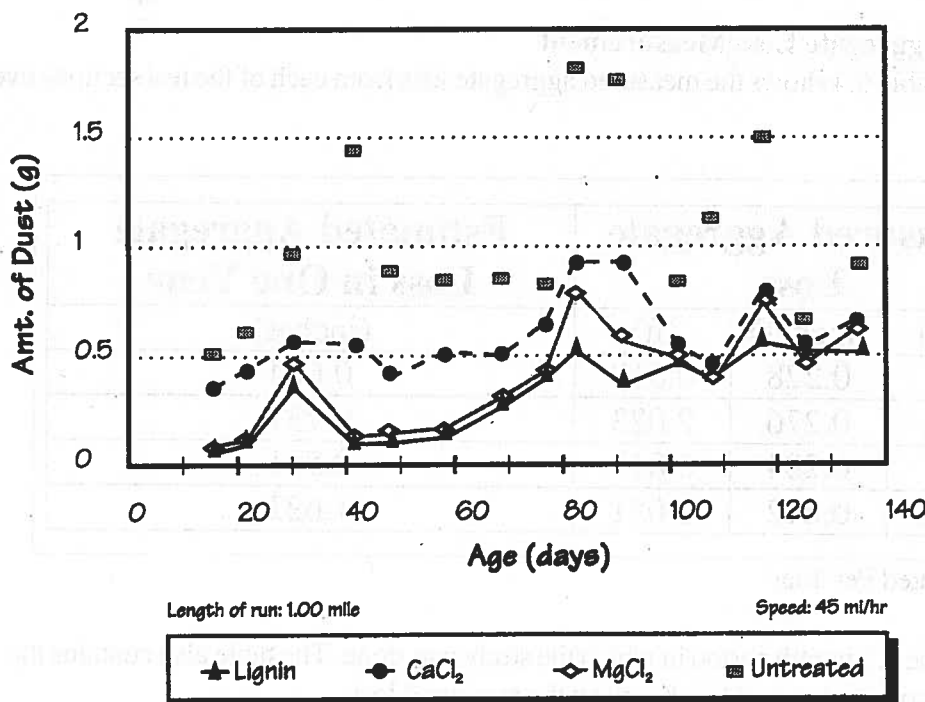

Figure 6.3-Amount of Dust Collected

0.4 gms of dust and had a high of about 0.9 gms, while the  $MgCl_2$  test section measured 0.08 gms of dust at the onset and had a high of approximately 0.7 gms measured towards the end of the test period. The untreated test section, however, averaged about 1.0 gm of dust measured each sampling period. It should be noted that the amounts of dust measured was only a portion of the dust generated by the left back wheel. Therefore, the dust measurements indicated only the relative effectiveness of each dust suppressant. It did not measure the amount of dust generated per vehicle.

From Figure 6.3, it is apparent that all the dust suppressants were effective in reducing the amount of dust generated when compared to the amount of dust from the untreated section. In addition, as the treated test sections aged the amount of dust emissions increased. This is indeed expected since, with time, the treatments lose their effectiveness and the continuous vehicular activities accelerate the loss of road surface fines. Table 6.2 also shows variations in the amount of dust sampled, these variations could be due to many factors, significant among them is the rainfall pattern during the test period. Depending upon the amount of rainfall and the prevailing weather condition prior to a dust measurement, higher or lower dust amounts could be measured. Rainfall events that did not produce runoff but gave the road surface just enough moisture to help vehicular compaction of the road surface and the rejuvenation of the dust suppressants in the case of the treated test sections, caused lower dust measurements. On the other hand, rainfall events that produced substantial runoff were noted to wash off the dust suppressants in the immediate top portion of the road surface allowing the fines to become loose and thus lost in the form of dust.

#### Aggregate Loss Measurement

Table 6.4 shows the measured aggregate loss from each of the test sections over

Test Section	Measured Aggregate Loss			Estimated Aggregate Loss in One Year
	(mm)	(inches)	(ft)	(inches)
Lignosulfonate	5.8	0.228	0.019	0.604
CaCl <sub>2</sub>	7.01	0.276	2.023	0.731
MgCl <sub>2</sub>	5.18	0.204	0.017	0.541
Untreated	15.55	0.612	0.051	1.622

Table 6.3-Inches of Dust Estimated Per Year

the 4.5 month period in which the study was done. The table also contains the estimated annual loss based on the measured loss.



The aggregate loss from the treated test sections were measured as 0.288 in. (5.80 mm) for the lignosulfonate, 0.276 in. (7.01 mm) for  $\text{CaCl}_2$  and 0.204 in. (5.18 mm) for  $\text{MgCl}_2$ . The untreated test section loss was 0.612 in. (15.55 mm) which is approximately 3-times more than that of the  $\text{MgCl}_2$  treated test section, 2.7 times more than the lignosulfonate treated test section and about 2-times more than the  $\text{CaCl}_2$  treated test section. These measurements are consistent with results of other studies. One reported aggregate pullout from treated unpaved road surfaces as approximately 25-75% that of untreated test sections; this research showed a 33-45% aggregate pullout.

Aggregate pullout from unpaved road surfaces is due primarily to vehicular movement and therefore, the volume of traffic using the road test sections would affect the total aggregate loss from the road test sections within a given time period. Since the traffic volumes for the road test sections evaluated were different, the aggregate loss from each test section can only be compared on a per vehicle basis. Table 6.4 shows the estimated total aggregate loss from each test section in tons/mile/year/vehicle. The estimated losses were computed considering a 33 ft (10 m) wide road and compacted density of 1.6 tons/yd<sup>3</sup> (note: road width does not have an impact on the amount of total aggregate loss).

The estimated total aggregate loss based on the 4.5 months measurement is 1.01 ton/mile/year/vehicle for the lignosulfonate treated test section, 1.49 and 1.04

Test Section	ADT	Measured Aggregate Loss/ mi/4.5 months (ft)	Estimated Aggregate Loss/ mi/year (ft)	Estimated Aggregate Loss/ mi/year (ton)	Estimated Aggregate Loss/ mi/year (ton)
Lignosulfonate	515	0.019	0.05	519.88	1.01
$\text{CaCl}_2$	421	0.023	0.061	629.33	1.49
$\text{MgCl}_2$	488	0	0.045	4665.16	1.04
Untreated	538	17	0.135	1395.47	2.59

Table 6.4-Tons of Aggregate Lost

tons/mile/year/vehicle for the  $\text{CaCl}_2$  and  $\text{MgCl}_2$  treated test sections respectively. The untreated test section on the other hand, loss an estimated total aggregate of 2.59 ton/mil/year/vehicle, 42-61% more than the treated test sections. Note that the estimated losses include: loss of fines in the form of vehicular-generated-dust and losses due to erosion (wind and rainfall).

### Cost Analysis

Some of the major problems associated with unpaved roads are aggregate

replacement cost and periodic maintenance cost. These items take a substantial portion of local government's budgets. In Larimer County, Colorado, for example, using 1994 budget figures, 12% of the total budget of the Road and Bridge Department was spent on aggregate replacement alone and another 17% on periodic maintenance of the nearly 700 miles of unpaved roads under the County's jurisdiction. The main economic reason for suppressing dust on unpaved roads is to prevent the loss of aggregate in the form of fines/dust as well as reduce the frequency of periodic maintenance required to keep the road surface in good condition. For this reason, in order for the relative effectiveness of the dust suppressants evaluated in this research to be ascertained, a cost accounting for each test section was done.

Table 6.5 represents the cost analysis. The unit prices of the three dust suppressants evaluated were the same at \$0.285 per gal. The total cost of material (suppressant), labor and equipment for placing the treatments was \$3,528 per mile for the lignosulfonate test section and \$2,768 per mile each for the CaCl<sub>2</sub> and MgCl<sub>2</sub> test sections. The lignosulfonate treatment cost \$760 more

Test Section	ADT	Measured Agg. Loss/ mi/ 4.5 months (ft)	Estimated Annual Agg. Loss/ mi (ft)	Estimated Annual Agg. Loss/ mi (ton)	Cost of Test Sections					
					Agg. Loss/ mi/ yr (dollars)	(M+L+E)/ mi/ yr (dollars)	PM/mi (dollars)	*- P-M/ yr	Actual Total Cost/ mi/ yr (dollars)	Actual Total Cost/ mi/ yr/ Veh (dollars)
Lignosulfonate	515	0.019	0.05	519.88	\$6,015	\$3,528	\$529	2	\$10,601	\$21
CaCl <sub>2</sub>	421	0.023	0.061	629.33	\$7,281	\$2,768	\$529	2	\$11,107	\$26
MgCl <sub>2</sub>	448	0.017	0.045	465.16	\$5,382	\$2,768	\$529	2	\$9,208	\$21
Untreated	538	0.051	0.135	1395.47	\$16,145	\$0	\$529	8	\$20,378	\$38

Table 6.5-Cost Per Mile to Maintain Test Sections

in labor and equipment than the CaCl<sub>2</sub> or MgCl<sub>2</sub> treatment. The difference was due to the different methods of applications of the lignosulfonate and the chloride compounds. A mixed-in-place application was used for the lignosulfonate treatment while a surfaced sprayed application was used for the chloride compounds treatments. The compacted density of the roadway was 1.6 tons/yd<sup>3</sup> and the cost to replace the estimated lost aggregate was \$11.57 per ton in place. The cost of periodic maintenance, which included the use of water trucks and compactors, was \$529 per mile. Based on the 4.5 months study period it was estimated that the untreated test section would required eight periodic maintenances during the year while the treated test sections would required only two periodic maintenances.

With reference to Table 6.5, the computed cost for the lignosulfonate treated test section per mile per year per vehicle is approximately \$21, the costs for the  $\text{CaCl}_2$  and  $\text{MgCl}_2$  treated test sections are \$26 and \$21 respectively. The untreated test section cost \$38/mi/yr/vehicle. This analysis indicates a 30-46% cost saving in the treated test sections over the untreated test section. The slight differences between the treated test sections costs could be just random and therefore not very significant. What is of importance, is the fact that the use of road dust suppressants reduced the overall total aggregate loss from the unpaved road surface as well as the frequency of periodic maintenance required to keep the road in good condition. This results in substantial cost savings especially when the ADT on the unpaved road is high.

Because of the high initial cost (material, labor and equipment) involved in applying dust suppressants, the question, "at what minimum ADT would the use of road dust suppressants be feasible?" was posed. The answer may be influenced by several factors, the most important of which is the cost of aggregate in place. Based on the aggregate loss measurement and cost figures for the different treatments studied in this research, Figure 6.4 was developed to answer this question. As mentioned previously the cost of aggregate in place was \$11.57/ton, the initial cost per mile of roadway per year in material (suppressant), labor and equipment for placing each treatment was \$3,528 for the lignosulfonate test section, \$2,768 each for the  $\text{CaCl}_2$  and  $\text{MgCl}_2$  test sections and \$529 for the untreated test section (Y-intercept Figure 6.4). The cost of periodic maintenance for each test section was \$529.00/mile. Two periodic maintenances per year was assumed for the treated test sections and 8 per year was assumed for the untreated test section. Based on the traffic count in this research, the cost of aggregate in place and periodic maintenance cost, the slope of each curve was established.

With reference to Figure 6.4, it is obvious that at low ADT it is more economical to leave the unpaved road untreated. As the ADT increases, the cost of maintaining the untreated road increases. The point where a treated test section curve crosses the untreated test section curve (indicated with vertical lines on Figure 6.4 at approximately 100 and 130) is the minimum ADT at which a particular treatment is economically feasible.

Since the cost of aggregate in place is such an important variable influencing the economics of this exercise, the minimum ADT's at which treatment is feasible was determined at different aggregate costs and the results are shown in Table 6.6.

Cost of Treatment v.s ADT

@ Aggregate Cost: \$11.57/ton in place

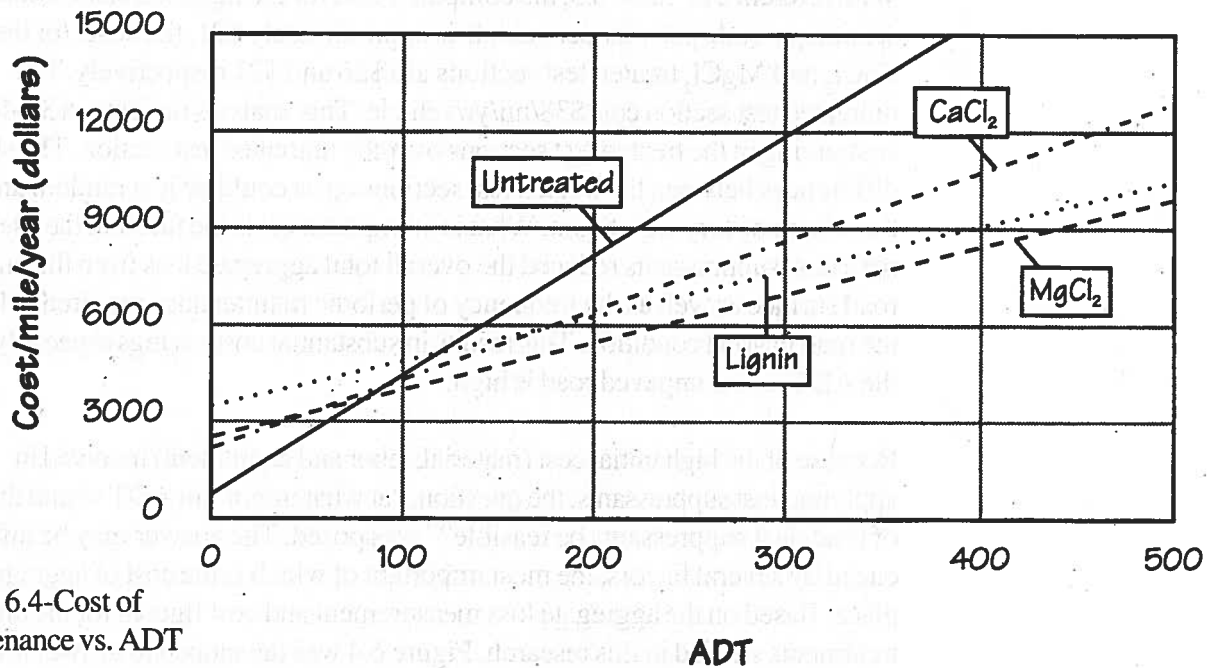

Figure 6.4-Cost of Maintenance vs. ADT

The procedure followed in establishing the minimum ADT's for the different aggregate costs is the same as described above. The minimum ADT's at

Cost of Aggregate per ton	Lignosulfonate	CaCl <sub>2</sub>	MgCl <sub>2</sub>
	ADT	ADT	ADT
\$5.00	232	225	180
\$7.50	180	180	140
\$11.57	130	130	100
\$15.00	105	105	80

Table 6.6-Average Daily Traffic When Dust Treatment Becomes Feasible

\$5.00/ton, \$7.50/ton and \$15.00/ton in addition to the \$11.57/ton were determined. From the results (Table 6.6) one can conclude that as the cost of aggregate in place increases, the minimum ADT at which the use of dust suppressants become economically feasible, decreases.

### Conclusions

The following conclusions are based upon results of this field based research. Dust measurement data indicate that there is a substantial reduction in fugitive dust emission with application of chemical dust suppressants (50-70% reduction). Under high temperature and low relative humidity conditions, the lignosulfonate treated test section appears to produce less dust than the test sections treated with the chloride compounds during the test period. However, field observations after the research was completed showed that the lignosulfonate test section produced equal or more dust than the chloride compounds. The driving comfort on the lignosulfonate treated test section was also found to be considerably less than on the chloride treated test sections, mainly because of pothole formations on the lignosulfonate test section after the test period.

There is an estimated total aggregate loss of 1.0 ton/mile/year/vehicle from the lignosulfonate treated test section, 1.5 tons/mile/year/vehicle from the  $\text{CaCl}_2$  treated test section, 1.0 ton/mile/year/vehicle from the  $\text{MgCl}_2$  treated test section and 2.6 tons/mile/year/vehicle from the untreated test section. This translates into a 42-61% reduction in total aggregate loss when unpaved roads are treated.

Cost analysis shows a 30-46% reduction in total annual maintenance cost for treated test sections over the untreated test section.

At ADT of over 120, the use of any of the dust suppressants evaluated proved to be cost effective. This is the traffic volume at which the economic feasibility of the use of dust suppressants will decrease as the cost of in place aggregate increases.

The minimum ADT at which the use of dust suppressants are economically feasible is variable depending on cost of aggregate in place.



## REFERENCES

1. *Asphalt Pavement Maintenance Reference Manual*, Maintenance and Equipment Division, Montana Department of Highways, 1983.
2. Roy Symons, *Motor Grader Operation and Maintenance Manual*, Maintenance and Equipment Division, Montana Department of Highways.
3. Roy Symons, *Motor Grader On-The-Job Training Sheets*, Maintenance and Equipment Division, Montana Department of Highways, September 1985.
4. *Maintenance of Aggregate and Earth Roads*, WA-RD 144.1, Washington State Department of Transportation, June 1987.
5. *Operator Handbook, Motor Grader Operator Short Course*, Nebraska Technology Transfer Center, 1988.
6. *Blading Aggregate Surfaces*, National Association of County Engineers Training Guide Series, US Department of Transportation, Federal Highway Administration, 1986, 1990.
7. *Maintenance of Gravel Roads Video Supplement*, North Carolina Institute for Transportation Research and Education, 1989. (See Video Tape Reference # 9.)
8. *The Asphalt Handbook*, Manual Series No. 4, 1989 Edition, The Asphalt Institute.
9. "Guidelines Needed for Road Crowns", *Technology News*, Iowa State University, February 1989.
10. "Gravel Road Maintenance Innovations", *Better Roads*, 58:12, page 27, December 1988.
11. *Standard Specifications for Road and Bridge Construction*, Montana Department of Highways, State of Montana, 1987 Edition.
12. *Operating Tips: Road Dust Suppressants*, Northwest Technology Transfer Center, Winter 1986.
13. "Dust Control, Road Maintenance Costs, Cut with Calcium Chloride", *Public Works*, May 1990. (Used with permission)
14. *When to Pave a Gravel Road, Helping Hand Guide #2*, Kentucky Transportation Center, April 1988.
15. "Installation of Geotextiles on Low Volume Roads", *Rural Technical Assistance Program Newsletter*, Oklahoma State University, July 1987.

16. Traffic Control Practices for Low Volume Local Roads, South Dakota Transportation Technology Transfer Service, 1993.
17. NACE Action Guide Volume III-1 "Road Surface Management", National Association of County Engineers Action Guide Series, 1992
18. The AASHTO Maintenance Manual (1976)
19. "Relative Effectiveness of Road Dust Suppressants", by T.G Sanders, J.Q. Addo, A. Ariniello and W.F. Heiden, Colorado State University, 1994.
20. "Problems Associated with Gravel Roads", U.S. Department of Transportation, Federal Highway Administration. Publication No. FHWA-SA-98-045, May 1998.
21. Local Roads Program, "Highway Drainage", Cornell University, May 1987.
22. Pavement Design, Principles and Practices. USDOT, FHWA, September 1987.
23. "Fundamentals of Geotechnical Analysis", Department of Civil Engineering, Utah State University, 1980.

## VIDEO TAPE REFERENCES

1. EO112 Operating Tips, Caterpillar Motor Grader 14-E, Articulating Caterpillar Motor Grader, 20 minutes.
2. EO111 Taking Control of Your Motor Grader (19 minutes) & How to Get More Out of Your Motor Grader (23 minutes), John Deere.
3. EO113,114,115 Motor Grader Operation – Part 1, Part 2, Part 3, Washington State Department of Transportation, 20 minutes each.
4. EO117 Blading Unpaved Roads, Federal Highway Administration, 22 minutes.
5. RM306 Rural Roads, A New Approach, Montana State University, 27 minutes.
6. RM307 Upgrading Gravel Roads, Montana State University, 21 minutes.
7. RM310 Maintenance of Gravel Roads (27 minutes), & Ditch Maintenance (17 minutes), with supplemental handbooks, North Carolina Institute for Transportation Research and Education.
8. RM311 Problems with Gravel Roads, Local Technical Assistance Program , 55 minutes.



**TO BORROW VIDEO REFERENCES (rent free), Call or Write:**

Local Technical Assistance Program  
Department of Civil Engineering  
Montana State University-Bozeman  
Bozeman, MT 59717-0390

or

**Call toll-free (800) 541-6671 or (406) 994-6100**





