

# 2020 INNOVATION CHAMPIONS CONTEST

(previously known as You Show Us Contest)

## CULVERT RACK

COUNTY: Stark County Highway Department

DESIGNERS: Randy Dillinger, Joe Messer

ADDRESS: PO Box 130 (52 30<sup>th</sup> Ave. W)  
Dickinson ND 58601

CONTACT: Al Heiser

E-MAIL: [milktank@ndsupernet.com](mailto:milktank@ndsupernet.com); [aheiser@starkcountynd.gov](mailto:aheiser@starkcountynd.gov)

TELEPHONE: (701)290-2256 (c)  
(701)456-7662

### **PROBLEM STATEMENT:**

The stocked supply of culverts in the county road department yard took up a lot of space. The culverts were stacked on the ground and on railroad ties against a fence. High winds would cause the stacked culverts to roll, sometimes for a significant distance from the yard. This required someone to spend time not only restacking them, but also chasing after those that had blown away. The bottom layer of culverts rested on the ground and would fill with silt and get rusty. Weeds grew around the culverts in the summer and in the winter they would freeze to the ground.

**SOLUTION:** Designed and fabricated a storage rack for the culverts. The culverts no longer roll off when stacked, blow away due to high winds, fill with silt and rust, or freeze to the ground. Weeds no longer grow between and around the culverts.

The culvert racks were designed to accommodate any size culvert. Typically two racks are spaced 14 feet apart to accommodate 20 foot culverts. They can however be placed closer together or further apart to accommodate any size culvert or other material such as bridge planks.

Each culvert rack is made from I-beams from an old bridge. The I-beams are cut to lengths of 20 feet, 6 feet and 2 feet. The 20-foot and 6-foot lengths are used to hold the culverts. The two-foot length is used as a support to keep the 6-foot I-beam upright. Gusset plates are cut and welded as reinforcement for the upright I-beam because stacked culverts put pressure on it.

Two-inch iron tubing is welded to the top of the 6-foot I-beam. This tubing is used as a lift point to move the rack with a forklift. Channel iron welded on the top end of each 20-

foot ground beam prevents the culverts from rolling off. Iron tubing welded to the underside end of each 20-foot ground beam creates a slight slant so culverts roll to the center of the rack.

## **EQUIPMENT, MATERIAL, LABOR:**

### **Equipment/tools used:**

Plasma arc  
Welder  
Handheld grinder  
Overhead crane

### **Materials: Iron used to make one set (2 culvert racks)**

#### **Salvage material:**

4 - 10" x 20' long bridge I-beams  
2 - 10" x 6' long bridge I-beams  
4 - 10" x 2' long bridge I-beams  
4 - 4" x 6" long channel iron  
2 - 2" x 6" tubing 6" long (used as lift point)  
4 - 4" x 4" x 6" tubing  
4 - 6" x 6" x 1/4" gusset plate

#### **New material:**

Welding wire – used 1/5 roll of solid core wire  
2 - 4 1/2" grinder wheels

### **Labor Hours:** *(Note: includes time needed for design and discussion)*

2 people – 2 hours for design and discussion  
1 person – 10 hours  
Total: 12 hours, for one set

### **COST SUMMARY:**

Welding wire - \$23  
Grinder wheels - \$16  
Total Cost: \$39 plus labor

**SAVINGS AND BENEFITS:**

Personnel can now focus on other tasks and no longer have to spend time restacking or chasing after culverts that blew away. Culverts are no longer on the ground, so they do not rust or freeze to the ground. Less space is used to store the culverts and the shop yard is more organized. The county now has the space to add another building in the yard. The county has experienced a savings in time and money and has seen efficiencies with the culvert racks.

**ANNUAL OPERATING COSTS:****Before using the innovation:**

Shop personnel would spend time restacking culverts so they wouldn't run them over after they had been blown around the yard. Retrieving culverts that had blown away or freeing culverts frozen to the ground would keep personnel from completing other duties. The bottom layer of stacked culverts setting on the ground would rust, and high weeds would grow around them.

**After using the innovation:**

With the racks, personnel can focus on other job responsibilities and tasks and do not need to redo a task previously completed. Culverts are not rusty before putting them to use on the roads. The county has experienced better use of personnel and county time, money and space.

**DRAWING (SCHEMATIC) WITH DETAILS:**

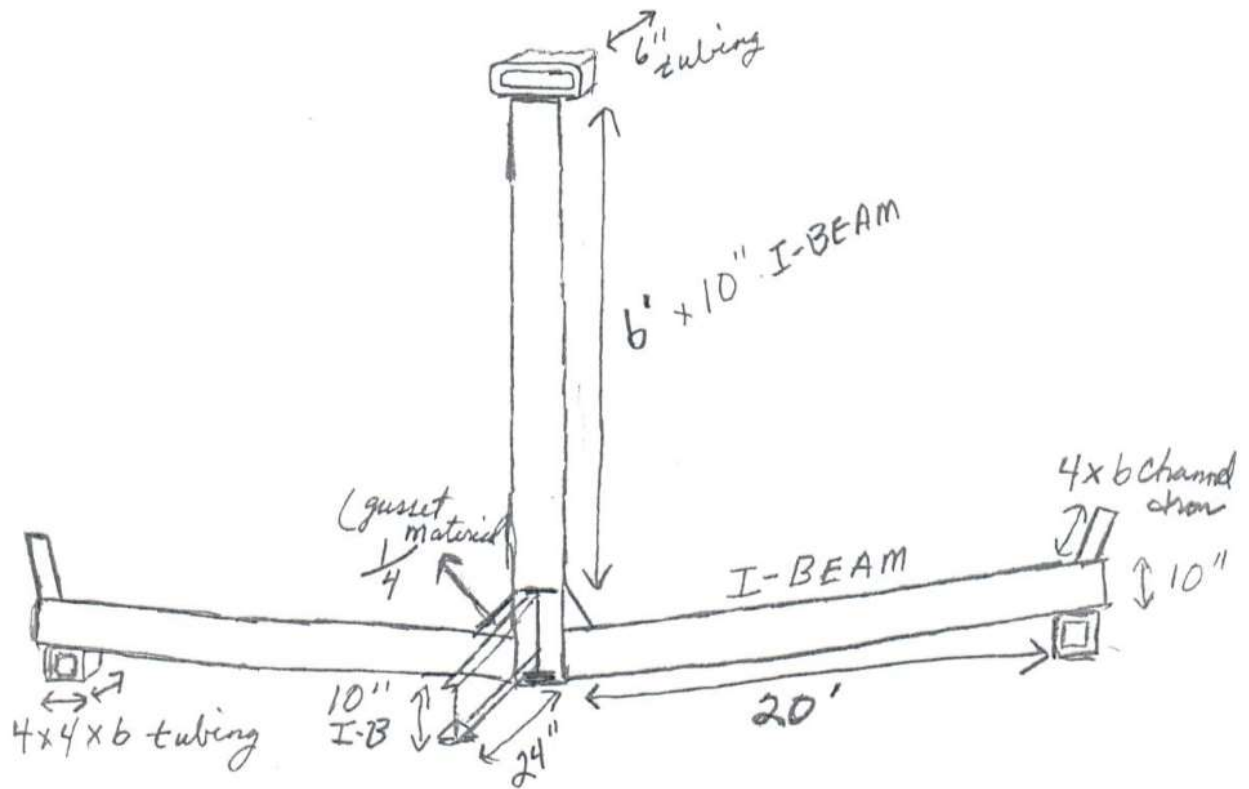

Culvert racks – one set, can be set apart or moved together to accommodate any size culvert.



Culvert racks keep culverts out of the dirt, off the ground, and organized.



Each culvert size sits on it own rack.



Gussets provide reinforcement for the 6-foot upright I-beam.





2-foot I-beams at the base keep the rack upright.



Channel iron and iron tubing at the end of each 20-foot I-beam prevents culverts from rolling off.



A lift point is welded to the top of each culvert rack so that it can be easily moved using a skid-steer loader.



Better utilization of yard space.

