

2017 YOU SHOW US CONTEST

CULVERT BLASTER

COUNTY: Dunn County, North Dakota

DESIGNERS: Rory Myran, Eldon Rohde

ADDRESS: Dunn County Road Department
300 Central Avenue South
Killdeer, ND 58640

CONTACT: Rory Myran

E-MAIL: lori.tabor@dunncountynd.org

TELEPHONE: (701)290-7323; Rory; (701)764-5546 Office

PROBLEM STATEMENT:

Culverts plugged by beaver activity, silt, rock and/or other debris do not allow water to flow properly. Backed up and ponding water causes the road to "soften." It is difficult to clean immersed culverts. Employee(s) would walk into the waste deep and higher water to loosen up the debris in the culvert. The risk of being sucked through the culvert once the water was released was

SOLUTION:

We created an innovative system that eliminates the necessity of going into water that is backed up behind a culvert. Details of our system are as follows:

- We used a 2-7/8 inch pipe that is retrofitted with flat iron brackets that attach to the bucket of a backhoe.
- The brackets attach to the bucket with bolts.
- Chain hooks are welded to the backhoe bucket.
- Chain is welded to the pipe and used to support the pipe when attached to the chain hooks on the bucket.
- A water line is attached to a water pump and to the pipe.
- The pipe is probed in and around the blockage inside the culvert.

The pump pushes water under pressure through the pipe and into the culvert. The water pressure dislodges the debris and forces it out the other end of the culvert.

LABOR, EQUIPMENT, AND MATERIAL USED:

The following equipment was used: Welder, cutting torch, grinder, drill

The following materials were used:

Water pump – 4 inch 700 gpm (gallons per minute)
Backhoe with 18 inch wide bucket
2 7/8" steel drill pipe - 14 feet long
1 – 3" 90 degree national pipe thread (NPT) elbow
1 – 3" cam lock male fitting
3' of 2 1/2" X 1/4" flat iron
Qty. 2 – 2" x 1/2" bolts
Qty. 2 – 1/2" nuts
7' of 3/8" log chain
Qty. 2 – 3/8" chain hooks

Total Labor Hours: 2 employees, approximately 4 hours
(Note: one hour to discuss and 3 hours to build)

DRAWING (SCHEMATIC) WITH DETAILS:

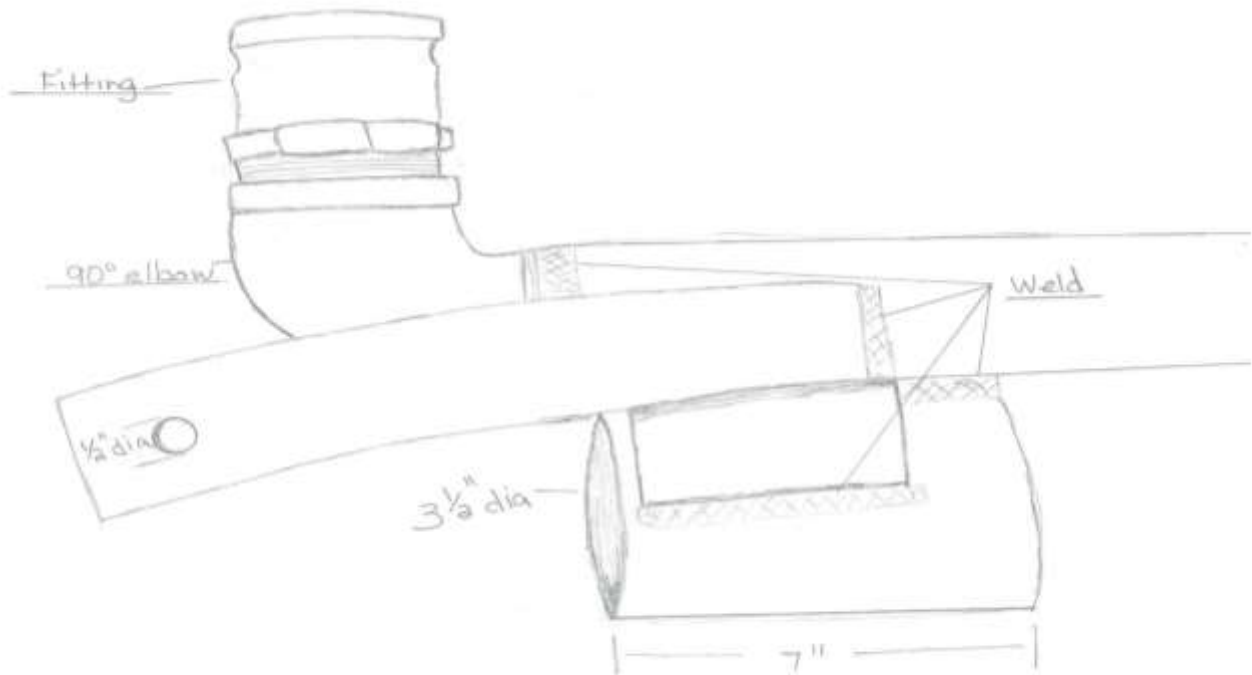

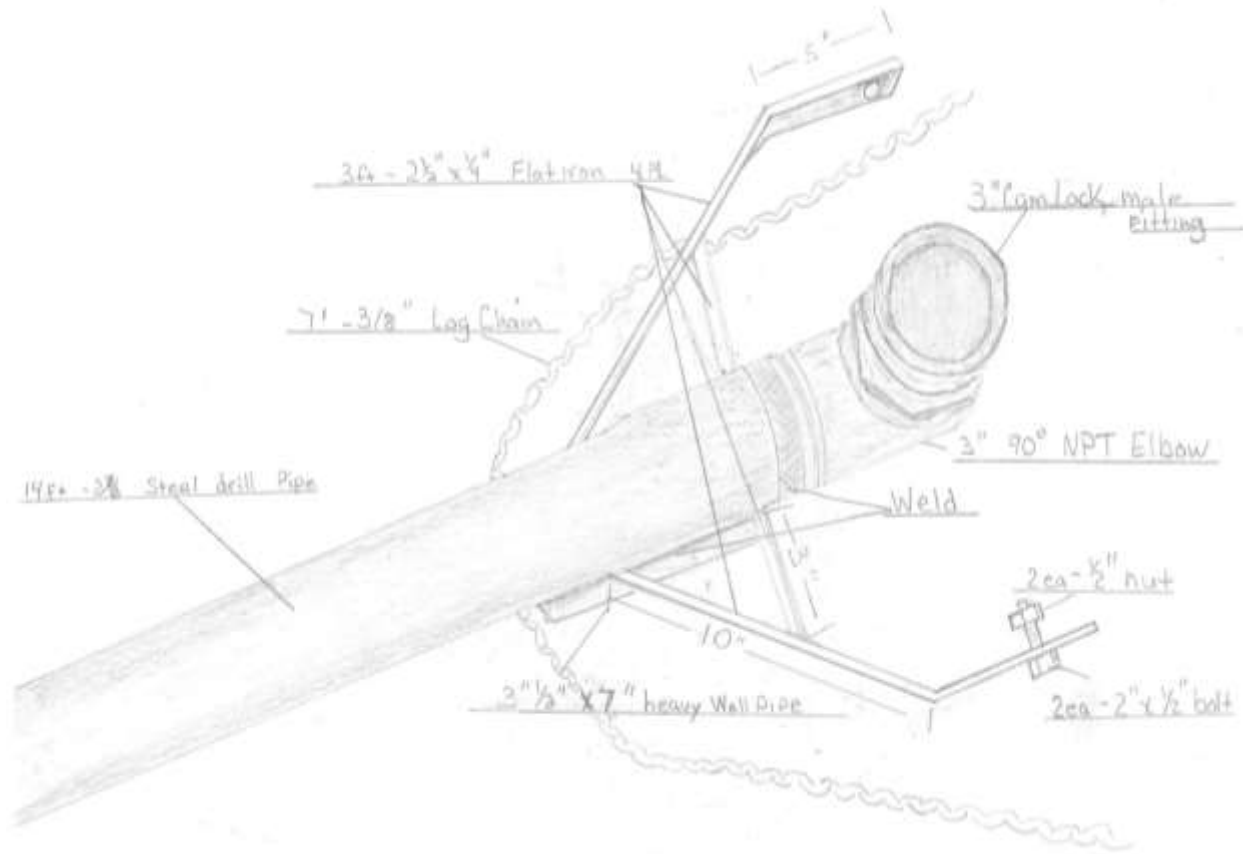

COST SUMMARY:

Utilize existing backhoe, water pump and hose. Most of the materials used were on hand. Below is an approximate cost:

- 2 7/8" steel drill pipe 14 feet long - \$25
- 1 - 3" 90 degree NPT elbow - \$15
- 1 - 3" cam lock male fitting - \$5
- 3' of 2 1/2" X 1/4" flat iron - \$5
- Qty. 2 - 2" x 1/2" bolts - a few cents
- Qty. 2 - 1/2" nuts - a few cents
- 7' of 3/8" log chain \$25
- Qty 2 - 3/8" chain hooks \$8

Total cost - \$83 plus labor

SAVINGS AND BENEFITS:

The county road department has experienced a savings in time, money, labor, and safety with the culvert blaster. There is no need to dig up the road to replace the culvert. Fewer staff are needed when using the culvert blaster as opposed to digging up the road and replacing the culvert. The road does not have to be closed. The cost savings to the county for this road project is up to \$3,000.

The safety benefit is that employee(s) do not have to get in the backed up water and risk getting sucked through the culvert when the blockage is released. Another safety benefit is the possibility of a motorist using a road that has been closed for construction is eliminated.

Before: partially plugged culvert.



Pipe bolted and chained to bucket, water line attached to pipe.



Flat iron brackets and chain welded to pipe.



Pipe with water line attached to bucket.



Pipe is probed in and around blockage inside culvert.



Water pump.



After: cleared culvert.

